

1014

INSTRUCTIONS AND APPLICATIONS

Beat Frequency Oscillator Type 1014



A beat frequency oscillator covering the range 20 to 20000 c/s. The apparatus is designed to meet the numerous requirements of a signal source for audio frequency work. It is excellently suited both for electrical and electroacoustical measurements, as well as for acoustic research.

Accelerometers
 Acoustic Standing Wave Apparatus
 Artificial Ears
 Artificial Voices
 Audio Frequency Response Tracers
 Audio Frequency Spectrometers
 Audio Frequency Vacuum-Tube Voltmeters
 Automatic A. F. Response and Spectrum Recorders
 Automatic Vibration-Exciter Control Generators
 Band-Pass Filter Sets
 Beat Frequency Oscillators
 Complex Modulus Apparatus
 Condenser Microphones
 Deviation Bridges
 Distortion Measuring Bridges
 Frequency Analyzers
 Frequency Measuring Bridges
 Hearing Aid Test Apparatus
 Heterodyne Voltmeters
 Level Recorders
 Megohmmeters
 Microphone Accessories
 Microphone Amplifiers
 Microphone Calibration Apparatus
 Noise Generators
 Pistonphones
 Polar Diagram Recorders
 Preamplifiers
 Precision Sound Level Meters
 Recording Paper
 Strain Gage Apparatus and Accessories
 Surface Roughness Meters
 Variable Frequency Rejection Filters
 VHF-Converters
 Vibration Pick-ups
 Vibration Pick-up Preamplifiers
 Wide Range Vacuum Tube Voltmeters

BRÜEL & KJÆR

Nærum, Denmark . Phone 80 05 00 . Telegrams: BRUKJA, Copenhagen



Beat Frequency Oscillator

Type 1014

Reprint January 1962

Contents

Description	5
General	5
Description of the Oscillator and Mixer-Section	6
Frequency Marking	9
Partial Blocking of Frequency Range	10
Description of the Output Amplifier Section	11
Power Supply	13
Operation	14
General	14
Calibration	15
Operation Using the Output Terminals Marked "Load"	15
Operation Using the Built-in Attenuator	16
Frequency Modulation	16
Automatic Recording	16
Marking Adjustment	20
Partial Blocking of Frequency Range	21
Automatic Regulation of the Output Power	22
Remote Control	23
Trouble Shooting	23
Accessories	24
Applications	25
Group A. Electronic Measurements	25
Measurement of Frequency Response of Four-Terminal Networks ..	25
A.C. Bridge Measurements	26
Measurements of Temperatures and Temperature Differences	27
Measurement of Gain in A.F. Amplifiers	30
Group B. Acoustical Measurements	30
Recording of the Frequency Response of Loudspeakers	30
Recording of the Frequency Response of Microphones	32
Recording the Frequency Characteristic of Hearing Aids and Ear-	
phones	33
Checking of Hearing Aids	35
Measurements on Air Filters, Carburettor Inlets etc.	36
Testing the Qualities of Airborne Sound Insulation	38
Measurement of Reverberation Time	39
Absorption Qualities on Sound Insulation Material	44

Group C. Mechanical Measurements	45
Strain Measurement on Vibrated Objects	45
The A.F. Response and Spectrum Recorder Type 3326	47
Description	47
The Audio Frequency Spectrometer	48
The Level Recorder	49
Recording Paper	50
Copying of Recorded Information	51
Operation	52
General	52
Synchronization	52
Applications	54
Automatically Recording Harmonics	54
Vibration Measurements	57
Noise Measurements	57
Specification	59

Description

General.

The Beat Frequency Oscillator Type 1014 is primarily designed for electrical and electro-acoustical measurements and consists of an oscillator- and mixer-section, and an amplifier section.

It works on the heterodyne principle using two high frequency oscillators, one of which operates on a fixed frequency, while the frequency of the other can be altered by a variable capacitor. The required audio frequency is then obtained as the difference between the two high frequencies and can be read off a large illuminated scale, the pointer of which is connected to the variable capacitor. The scale is logarithmic and graduated from 20 to 20000 c/s. An "Incremental Scale" is also provided, allowing exact frequency selection in the range -50 to $+50$ c/s around any setting on the main scale.

The zero-adjustment is carried out by obtaining a beat between the frequency of the mains voltage, and that of the oscillator voltage occurring when the oscillator is tuned to the frequency of the mains and the pressbutton marked "Power Frequency Beat" on the front panel of the oscillator is pressed.

The variable capacitor has two control knobs, one of which is in a fixed position on the capacitor spindle and is used for quick setting to the desired frequency. The other will, when depressed, rotate the spindle with a ratio of 1 to 5 giving greater accuracy and final selection of the frequency.

A worm gear permits the capacitor to be tuned automatically, for example, with the aid of the motor of the Level Recorder Type 2305. The mechanical connection to the Level Recorder is effected by means of a flexible shaft which can be screwed onto the bushing on the side of the Oscillator's cabinet during which the motor should be kept running. The worm gear can be engaged and released with the aid of a built-in electromagnetic clutch, operated from a switch on the front panel, or by a remote control arrangement. The electromagnetic clutch is a friction-device allowing manual tuning of the variable capacitor even when the clutch is engaged.

Being also designed for use in room-acoustical measurements, the Beat Frequency Oscillator is equipped with frequency modulation, for which a reactance tube controlled by saw-tooth oscillations from a built-in oscillator is switched into the circuit of the fixed oscillator. Both the frequency and the amplitude of the saw-tooth oscillation are adjustable and may be read off two printed dials. Provision is also made for external modulation, whereby very wide limits of frequency modulation can be obtained.

By means of a compressor circuit, which can be controlled from an external

voltage, it is possible to keep the voltage, current, or sound pressure constant during measurements when using the oscillator as a power source.

Description of the Oscillator and Mixer-Section.

Fig. 1 shows a block diagram of the complete Oscillator.

The fixed oscillator is tuned to 120 kc/s and can be frequency modulated. The

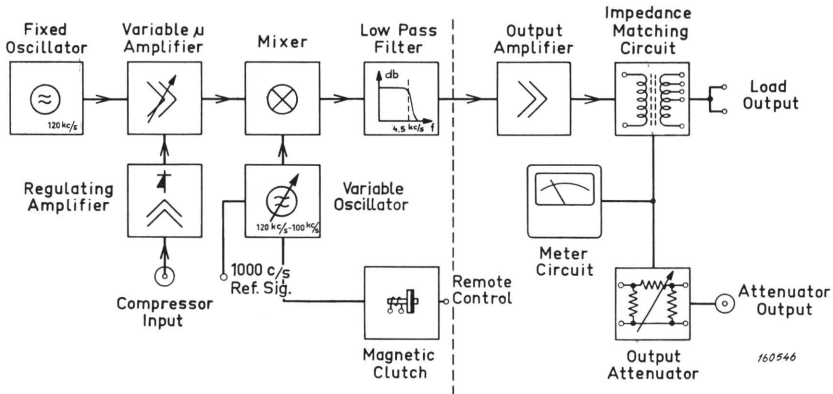

Fig. 1. Block Diagram of the Beat Frequency Oscillator 1014.

reactance tube circuit acts as a variable inductance and the modulation swing can be continuously varied from 0 to ± 200 c/s by means of a potentiometer on the front panel of the apparatus, marked "Modulation Swing".

By means of the switch marked "Modulation Frequency" the frequency of the built-in saw-tooth oscillator may be chosen. Frequencies of 1—2—4—8—16 and 32 c/s are available. The oscillator is a blocking type, tuned to approximately 7 Mc/s, and the frequency of the saw-tooth oscillations is set by changing the grid resistor.

Provision is made for external modulation. The external generator should then be connected to two terminals of the socket on the front plate marked "Remote Control". For external modulation a voltage of approximately 7 volts is necessary when a modulation swing of ± 200 c/s is required. The impedance of the external generator must be low (approx. $1 \text{ k}\Omega$).

When external modulation is employed the switch marked "Modulation Frequency" must not be in position "Mod. Off.", as in this position of the switch the reactance tube is cut off.

A variable capacitor of 60 pF, inserted in the tuned circuit of the fixed oscillator, and operated by the knob marked "Frequency Increment", permits exact frequency selection in the range ± 50 c/s for any setting on the main scale.

By means of a noiseless switch on the front panel, marked "Oscillator Stop", the voltage on the anode of the 120 kc/s oscillator can be disconnected. This

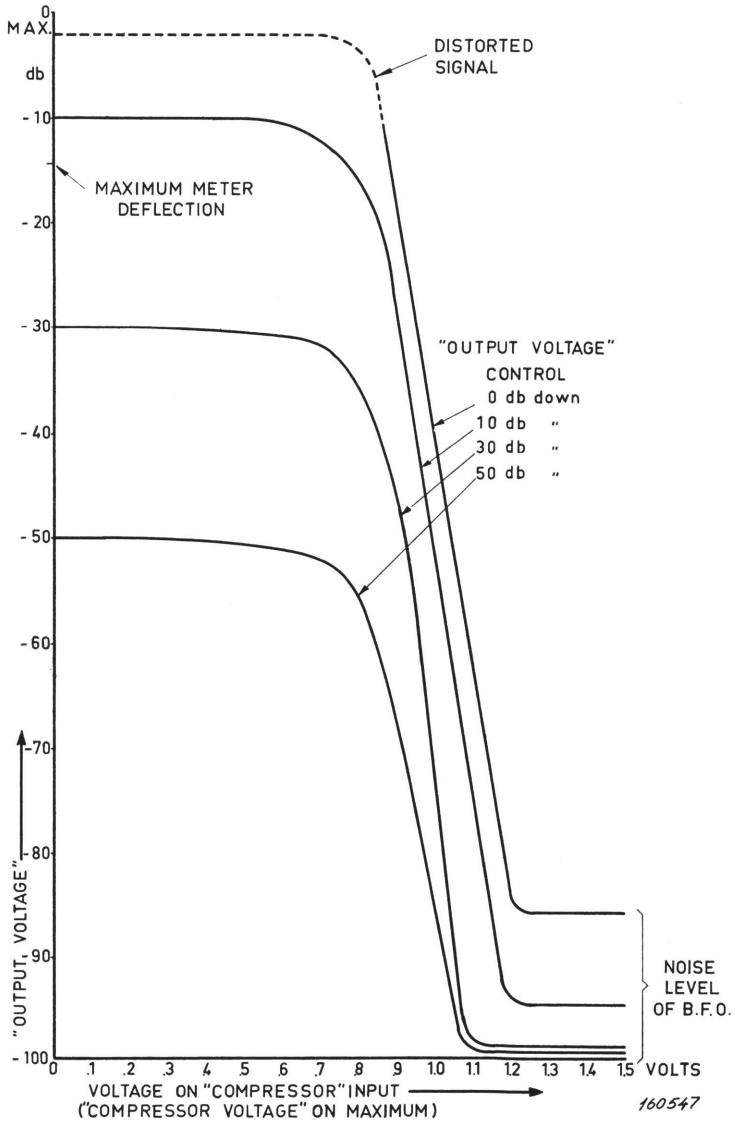

Fig. 2. Regulation Characteristics for different positions of the potentiometer marked "Output Voltage".

innovation is specially provided for reverberation measurements. The same method is used for remote control, the appropriate wiring of which can be seen by referring to the circuit diagram of the Oscillator.

The output voltage from the fixed oscillator is fed to the grid circuit of a pentode, the grid bias of which, is controlled, by means of a regulating amplifier. To obtain a higher degree of control the working-point of the pentode is chosen on the non-linear portion of the Ia-Eg characteristic, near cut-off.

The purpose of this circuit is to control automatically the output power of the Beat-Frequency Oscillator by an A.F. control voltage. For example, the voltage from a standard microphone placed in the sound field of a loud-speaker which is fed from the Oscillator. In this case the output power of the Oscillator will be so controlled that a constant sound pressure is maintained on the standard microphone.

The A.F. control voltage should be fed onto the screened socket marked "Compressor Input" on the front panel of the Oscillator. A variable potentiometer, marked "Compressor Voltage" is inserted in the input circuit of the regulating amplifier and can be used as volume control for the output power from the Oscillator when automatic regulation is employed. The regulating amplifier has a linear frequency characteristic from 20 to 20000 c/s and should have an input signal of approximately 1 volt on the grid of the A.F. amplifier tube for full regulation. The input impedance, measured across the terminals of the socket marked "Compressor Input" is approximately 100 k Ω , and the maximum obtainable range of regulation is 45 db.

The amplified A.F. control voltage is rectified in a full-wave double-diode rectifier, designed to give a DC output voltage proportional to the average value of the A.F.-control voltage.

By means of the switch marked "Compressor Speed" on the front panel of the oscillator the regulation speed can be varied. Regulation speeds of 30—100—300 or 1000 db/sec. may be chosen by changing the value of the capacitor in the A-C filtering network for the rectified control voltage. When the switch "Compressor Speed" is in position "Comp. Off." the output from the rectifier is short-circuited thereby disconnecting the automatic regulation circuit.

To make regulation of the output level possible, even when maximum output power is required from the Oscillator, the level of the high frequency voltage from the 120 kc/s fixed Oscillator is raised 10—15 db when the automatic compression is switched in.

The anode-circuit of the pentode in the variable- μ amplifier is tuned to 120 kc/s, forming a band-pass filter, the output of which is fed to the mixer. In the mixer tube, which is one half of a twin triode, the 120 kc/s voltage is mixed with the output voltage from the variable oscillator. The frequency of the variable oscillator can be altered continuously from 120 to 100 kc/s by means of a specially designed variable capacitor. This capacitor is made

with a high degree of accuracy and a maximum deviation of 0.7 degrees from a logarithmic frequency curve is obtained. A worm gear, connected to the capacitor spindle, permits automatic tuning with the aid of an external motor, for example the motor in the Level Recorder Type 2305, and the worm gear can be set and released by means of a magnetic clutch. This is operated from a switch on the front panel of the oscillator, or it can be operated from an external switch or relay. Connection must then be made to the appropriate terminals of the socket marked "Remote Control" on the front panel, and the control switch for the magnetic clutch must be in position "Clutch On".

By means of a pushbutton marked "1000 c/s Ref. Signal" an extra capacitor is introduced in the tuning circuit of the variable oscillator. This changes the frequency of the oscillator so as to increase the output frequency an amount of 980 c/s. With the scale pointer set to 20 c/s the output frequency is thus 1000 c/s and may be used for adjustment purposes as explained on page 19, item 17.

As previously mentioned, the frequency scale is logarithmic and calibrated 20—20000 c/s. When the capacitor is set to frequencies above 20000 c/s or below 20 c/s the fixed Oscillator is blocked, and consequently no output voltage will be obtained. For automatic recording of frequency characteristics, i.e. when using the Level Recorder Type 2305, this is a great advantage as no unwanted curves will then appear on the corresponding section of the frequency calibrated paper.

The voltage developed across the grid circuit of the variable capacitor is fed into the mixer tube and mixed with the voltage from the variable- μ amplifier. The mixer tube is of the triode type, whereby a low hum level is obtained in spite of the AC-heating of the filament.

A low-pass filter having a cut-off frequency of 50 kc/s is inserted in the anode circuit of the mixer tube, thus passing only the lower frequency obtained by the frequency conversion, onto the grid circuit of the first tube in the output amplifier section.

Frequency Marking.

An arrangement, which can be operated by the control switch for the magnetic clutch, is the marking of a certain frequency. At this frequency the fixed Oscillator is short-circuited, while at all other frequencies the normal output voltage is available. Basically, the blocking is effected by closing a pair of relay contacts. These contacts are operated by a cam disc which is mounted concentrically on the tuning capacitor spindle. Normally the cam rotates with the spindle, being held in position by a spring-loaded friction clutch. However, by means of a pawl the cam disc can be located at the point of its cycle where the short circuiting relay is closed.

This is carried out by setting the control switch for the magnetic clutch to position "Marking Adjustment", and turning the capacitor spindle until a

small "click" is heard. Because of the friction clutch, it is now possible to turn the capacitor and the scale pointer relative to, and independent of the cam. Release of the pawl, by means of the control switch, permits the cam to rotate once again with the capacitor.

Partial Blocking of Frequency Range.

When employing the special cam disc OD 0065 delivered with the B.F.O., a part of the frequency range can be blocked, i.e. the output signal is interrupted. The cam disc operates the same relay arrangement as used for the frequency marking. The range length which can be blocked corresponds to approximately two decades. This means that any range from 20 c/s up to approximately 2000 c/s, and from 20000 c/s down to approximately 200 c/s can be blocked in addition to the normal blocking outside the scale graduation. In Fig. 3 is illustrated the ranges obtainable. The two hatched ranges represent the blocking ranges. The range indicated by "Fixed" is the normal blocking arrangement which functions outside the scale graduation. The other range can be added to the normal, as shown in the figure, or it can function discontinued. A complete instruction of the mounting of the cam disc will be found under part Operation.

In applications where the B.F.O. is employed in conjunction with the B & K Level Recorder, and where automatic recording is employed, the blocking arrangement can also be used for remote lifting of the Level Recorder's

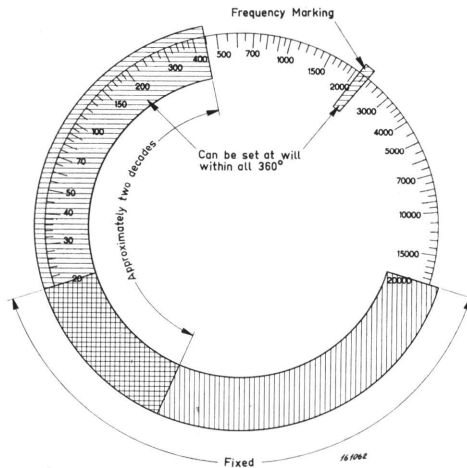

Fig. 3. The two blocking arrangements: Frequency Marking and Partial Blocking of Frequency Range.

writing pen. This is a great asset in for example measurements where the compressor circuit of the B.F.O. is used. In this instance the pen-lifting arrangement of the Level Recorder can be controlled from the frequency blocking circuit by making the appropriate connections to the "Remote Control" jack of the B.F.O. In cases where the entire frequency range (20—20000 c/s) of the B.F.O. is utilized, the normal frequency blocking, which functions outside the scale graduation, should be set out of operation. The writing pen of the Level Recorder can now be lifted from the paper outside the frequency range of interest and a proper working of the sompressor also at the initial frequency (20 c/s) is ensured during the automatic scan. If the described method is not utilized, the following would take place: No signal will be present in the range 20000 c/s to 20 c/s (outside the scale graduation), i.e. the compressor of the B.F.O. will be in such a condition to give full output signal of the B.F.O. Consequently, when the scale pointer goes inside the scale graduation (20 c/s) full output level will be transmitted at 20 c/s, and first after the chosen time delay (Compressor Speed) the signal level will be compressed to the proper (preset) value. A deflection on the recording paper which is not a response of the measured object would thus be recorded.

Description of the Output Amplifier Section.

The voltage from the low-pass filter is fed to the control grid of the first tube in the two-stage audio frequency output amplifier via a variable potentiometer. This potentiometer is operated by the knob marked "Output Voltage" on the front panel of the Oscillator and is used for continuous adjustment of the output power.

The gain of the amplifier is stabilized by means of negative voltage feedback, and the anode circuit of the output tube is coupled to an auto-transformer for impedance matching.

Four different output impedances are available and can be chosen with the switch on the front panel marked "Matching Impedance". The different positions of the switch are indicated by 6, 60, 600 and 6000 ohms respectively, and the output voltage is taken from the terminals marked "Load". It should be noted that the output impedance of the Oscillator is only approximately 10—20 % of the indicated values, but with correct loading a maximum output power is obtained with a minimum harmonic content. Furthermore, correct loading ensures the output voltage to be practically independent of the frequency.

A fifth position of the switch "Matching Impedance" is marked "Att." and connects the output transformer to an attenuator, variable in steps of 10 db from 120 μ volts to 12 volts, and is operated by the switch marked "Attenuator" on the front panel. With the impedance switch in this position the output circuit is connected to the screened socket on top of the front panel,

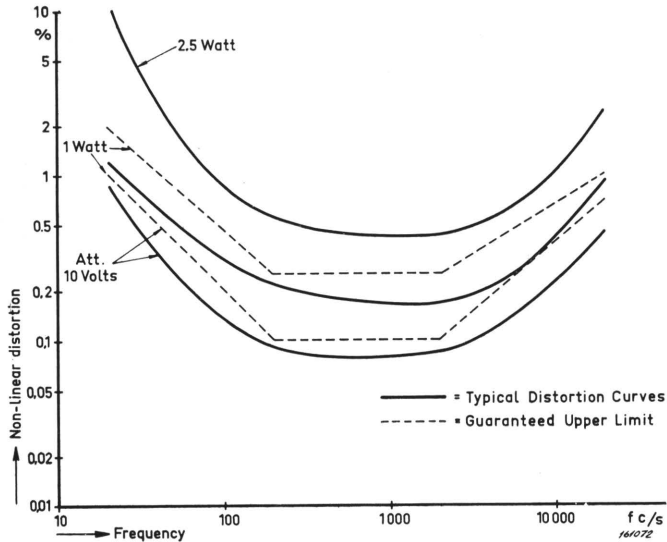

Fig. 4. Distortion curves for different loads. The curve marked "Att. 10 volts" is obtained from measurements taken on the "Attenuator" output terminals: open circuit.

the output impedance being constant and approximately 50 ohms. The overall accuracy of the attenuator is approximately 2 %.

The voltage on the output terminals is indicated by a vacuum-tube voltmeter which measures the average value of the A.F. voltage. It is calibrated in r.m.s. values of a sinusoidal voltage, and the accuracy in the frequency range 20—20000 c/s is 1.5 % of full scale deflection.

The sensitivity of the voltmeter is automatically changed when the position of the switch marked "Matching Impedance" is altered. Full deflection of the meter is indicated on the switch. When the "Matching Impedance" switch is in position "Att." the output voltage available from the Oscillator will depend on the position of the "Attenuator" switch, in this case full deflection of the meter corresponds to the value indicated by the switch position.

The signal-to-noise ratio of the Oscillator is greater than 70 db for maximum output voltage. It is independent of the position of the attenuator, but somewhat dependent on the position of the potentiometer marked "Output Voltage". The best result is obtained when this is positioned on or around the point marked 8.

Harmonic distortion is dependent on the setting of the "Output Voltage Potentiometer". The distortion increases as the output voltage is increased, but as long as the output is kept within the meter range, the distortion will be of the order indicated in Fig. 4.

Power Supply.

The Oscillator can be operated from a 240, 220, 150, 127, 115 or 100 volts AC power line, the power consumption being about 70 watts.

The proper voltage is selectable by a switch-fuse combination situated at the rear of the instrument. To select the voltage it is necessary to firstly remove the fuse by turning the hexagonal disc head in the centre of the switch anti-clockwise. Then with the aid of a screwdriver turn the head of the voltage adjuster until the white mark is aligned with the required voltage. The fuse is then replaced.

It should be noted that if the apparatus is to be operated from a DC power line, or from an accumulator, a vibrator unit or a rotary converter is required.

Operation

General.

Firstly ascertain that the Beat Frequency Oscillator is set to the appropriate power supply voltage by means of the selector at the rear of the instrument and that the Remote Control plug on the front panel is firmly in its place.

After connection to the power supply, the instrument can be switched on by the toggle switch marked "Power" on the front panel. The dial lights in the meter and in the frequency scale should immediately come on.

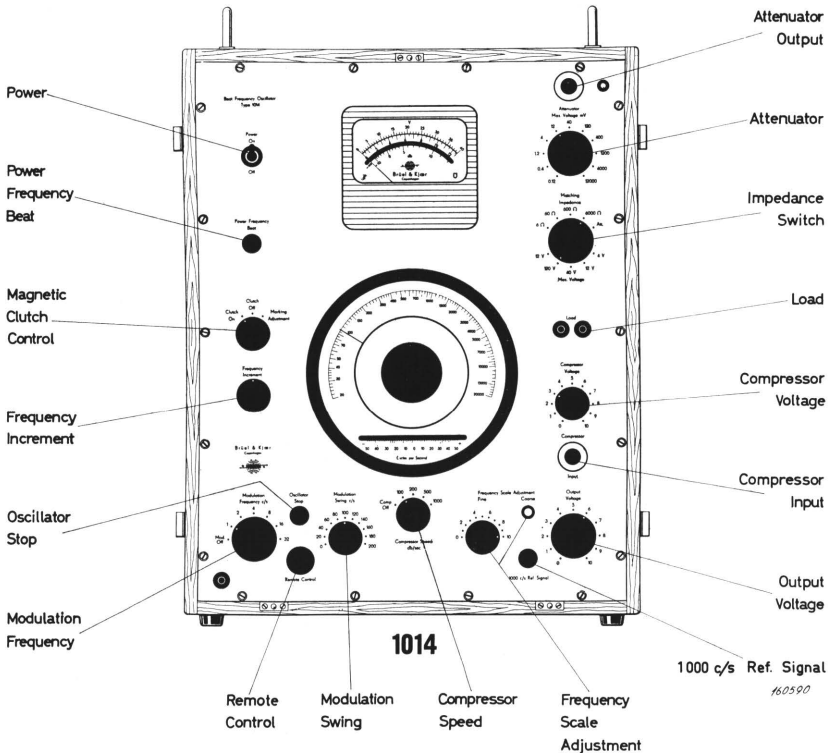

Fig. 5. Drawing of the Oscillator 1014.

A. Calibration.

1. Turn the toggle switch marked "Power" to "On" and allow two minutes warm up.
2. Set "Modulation Frequency" and "Compressor Speed" to their "Off" position.
3. Set "Clutch, Marking" to "Marking Adjustment" position. Rotate the main scale until a small click is heard and extra weight is felt on the drive. Continue to rotate until the pointer is set within uncalibrated portion of scale, i.e. between 20000 c/s and 20 c/s. Then return clutch switch to "Off".
4. Now turn main scale pointer until it is on the frequency of the line voltage (e.g. 50 or 60 c/s), checking that the frequency incremental scale is on zero. If not, set by "Frequency Increment" knob to this point.
5. Set suitable deflection on the meter by tuning the knob marked "Output Voltage" to higher than center scale reading.
6. Press "Power Frequency Beat" button and hold to "in" position and at the same time rotate "Frequency Scale Adjustment Fine" slowly, until a large fluctuation registers, slows up, and practically ceases on the meter dial. Two points may be found where this occurs, only one of which is correct and therefore a check as outlined in the following paragraph should be carried out, firstly releasing the "Power Frequency Beat" button.
7. Turn the main scale pointer to 20 c/s and with the "Frequency Increment" knob reduce scale reading to -20 c/s or -30 c/s depending upon supply frequency in use. If the frequency is correct the meter needle will drop to zero indicating that the B.F.O. is properly tuned. If it does not reach zero, repeat procedure from item 4.
8. Finally return "Frequency Increment" to zero. The B.F.O. is ready for use.

N.B. If a zero point cannot be found and is outside the range of the "Frequency Scale Adjustment Fine", re-align the variable capacitor marked "Coarse" with a screwdriver to give a suitable setting, which should occur at some point between 4 and 6 on "Frequency Scale Adjustment Fine".

B. Operation Using the Output Terminals Marked "Load".

Apply the following procedure:—

1. Set-up and calibrate the oscillator as described in A.
2. Place the "Matching Impedance" switch in a suitable position for the application.
N.B. Full deflection of the instrument meter corresponds to the voltage indicated by the switch position.
3. Connect the load to the output terminals marked "Load".
N.B. Right terminal is grounded.

4. Turn the pointer on the main frequency dial to the desired frequency, finely adjusting the Frequency Increment if necessary. (For automatic frequency sweep, see under E).
5. Select a suitable output voltage by turning the knob marked "Output Voltage".

C. Operation Using the Built-in Attenuator.

Apply the following procedure:—

1. Set-up and calibrate the oscillator as described in A.
2. Set the "Matching Impedance" switch in the position "Att."
3. Select the appropriate voltage range by means of "Attenuator".
N.B. Full deflection of the instrument meter corresponds to the voltage indicated by the switch position.
4. Connect the load to the screened output socket on the top of the instrument marked "Attenuator".
5. Proceed as in B. 4 and 5.

D. Frequency Modulation.

When a frequency modulated output signal is required, the following procedure should be adopted:—

1. Turn the knob marked "Modulation Frequency" to the required frequency.
2. Turn the knob marked "Modulation Swing" to zero.
3. Re-calibrate the Oscillator as described in A.
4. Set the "Modulation Swing" knob to the required frequency swing (bandwidth).
5. Proceed as described in B items 2 to 5, or C items 2 to 5, dependent on the requirement.

E. Automatic Recording.

By combining B.F.O. Type 1014 and Level Recorder Type 2305, or using Automatic Frequency Response Recorder Type 3304, it is possible to automatically record the frequency response of four terminal networks. When using B.F.O. Type 1014 and Level Recorder 2305, it is necessary to connect the two instruments mechanically by a Flexible Shaft UB 0040 as in Fig. 6 and to make the electrical connections also shown. Fig. 7 depicts the use of the Automatic Frequency Response Recorder Type 3304 with the required external connections.

For setting-up, calibrating and synchronising the combination shown in Fig. 6 the following procedure should be adopted:—

1. Ensure power supplies are correct and switch power toggles to the "On" position.

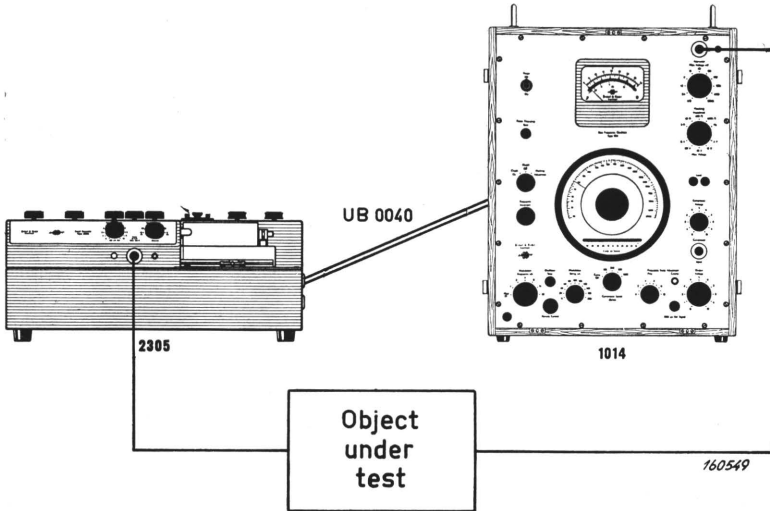

Fig. 6. Example of Mechanically Connecting the BFO 1014 to Level Recorder Type 2305.

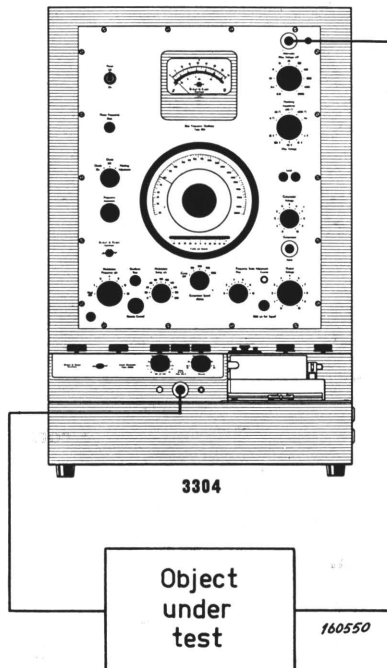

Fig. 7. External Electrical Connections when using Automatic Frequency Response Recorder Type 3304.

2. Calibrate the B.F.O. as described in A.
3. Connect the instruments as shown in Fig. 6. This is done by connecting a flexible driving cable (UB 0040) to the upper driving shaft of the Recorder "Drive Shaft I" located at the right-hand side and to the front of the Level Recorder. Taking the other end of the cable, insert and screw in drive on left-hand side of B.F.O. (Check engagement by switching the Level Recorder "Start/Stop" switch to "Start" and the B.F.O. magnetic clutch to "On" and note if scale pointer rotates).
4. Switching "Paper Drive" to "Stop", continue with the following procedure referring Fig. 8.

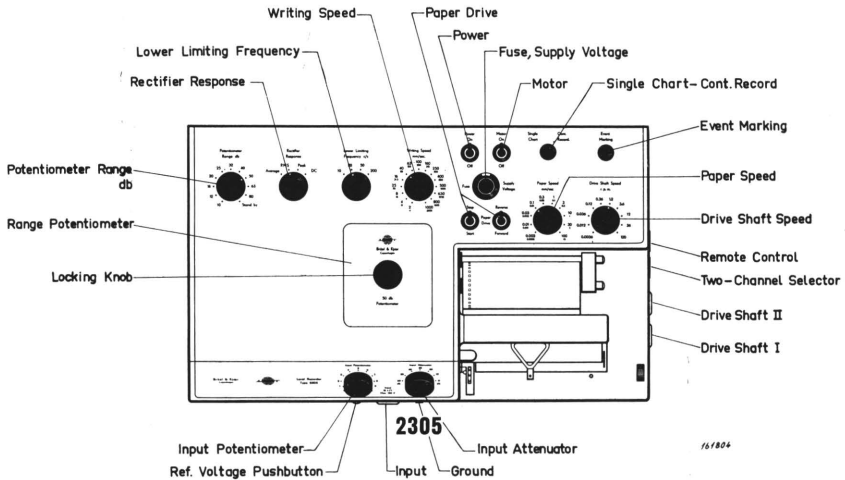

Fig. 8. Level Recorder Type 2305 viewed from above.

5. Load the Level Recorder with the desired recording paper. (Follow instructions in Level Recorder Manual).
6. Select and insert required Range Potentiometer. (N.B. Place "Potentiometer Range db" switch to "Standby" when changing potentiometers).
7. Switch "Potentiometer Range db" until figure corresponds to the Range Potentiometer being used, i.e. "10", "25", "50" or "80".
8. By means of the switch "Rectifier Response", select R.M.S. or if specially required one of the other three positions Average, Peak, or D.C.
9. Turn the "Lower Limiting Frequency" switch to the cut-off value (10, 20, 50 or 200 c/s).
10. Set "Writing Speed" to required position.
(Full explanations of items 8, 9 and 10 can be obtained from the Level Recorder Manual).

11. Place "Reverse/Forward" switch to "Forward".
12. Select "Paper Speed" to a suitable speed, e.g. 10 mm/sec.
13. Pull gear-lever marked "x" to the outer position. (See Fig. 36).
The actual paper drive speed now corresponds to the *small numbers* marked around the "Paper Speed" knob.
14. Two types of recording can be made:—
 - (a) Single chart recording (automatic recording over a length of 250 mm paper only),
 - (b) Continuous recording over any length of paper.

(a) **Single Chart Recording:**

Set the "Paper Drive" toggle switch to "Start" commencing the paper to run, which will continue until the built-in automatic stop switch declutches the drive mechanism (less than one chart length).

Reset recording paper by finger wheel "Z" (Fig. 36) until the stylus rests on, for instance, the 10 c/s line.

A chart of 250 mm length will now run off when the "Single Chart — Continuous Recording" pushbutton is pressed and released again immediately afterwards. (It is possible to stop the recording at any time by setting the "Paper Drive" toggle switch to "Stop").

(b) **Continuous Recording:**

The operator should follow the instructions outlined under (a), i.e. "Single Chart Recording", except that to start the recording it is necessary to press the "Single Chart — Continuous Recording" push-button and turn it clockwise. Recording will now automatically take place until the push-button is released again and the "Paper Drive, Start-Stop" toggle switch is set to "Stop".

Note: Whenever the "Paper Drive, Start-Stop" toggle switch is in the "Stop" position the paper drive is completely controlled by the "Single Chart — Continuous Recording" push-button.

15. In order to synchronise the units, stop the paper so that the stylus rests on the 20 c/s line.
16. Adjust the commencing of the reference line on the paper to a suitable level, any necessary fine adjustment being made with the Input Potentiometer.
17. Set the pointer of the B.F.O. on 20 c/s and engage the magnetic clutch by use of the clutch switch. The units should then be synchronised.
18. Push the "1000 c/s Ref. Signal" button. The B.F.O. then generates a signal of 1000 c/s enabling the operator to select a reference signal which is in the middle of the range. (This makes certain that when

taking a recording of frequency characteristics, where the lowest attenuation is around 1000 c/s, that the deflection of the stylus lies within the scalar limits of the paper during the recording).

Continuous Recording with ten Times Enlarged Paper Speed.

The following method is adopted: Set the "1 : 10 Synchronizing Gear Lever" in its inner position (released). The actual paper drive speed then corresponds to the *large numbers* marked around the "Paper Speed" knob. Recording on frequency calibrated paper is not possible in this position.

The start and stop of the recording will in this case be completely controlled by means of the "Paper Drive, Start-Stop" toggle switch.

F. Marking Adjustment.

Should an identity mark at some particular frequency be desired the following procedure should be used:—

1. Set the magnetic clutch control switch to the position "Marking Adjustment".
2. Turn the pointer of the main frequency dial until a small "click" is heard, the click being associated with an increased effort in turning the pointer.
3. Set the pointer to the frequency at which marking is desired.
4. Release the magnetic clutch control from the Marking Adjustment position, reverting to clutch "Off" or "On" as required.

The instrument is now operable as in B, C, D or E the output voltage disappears at the "marked" frequency.

G. Partial Blocking of Frequency Range.

When replacing the cam disc E (refer Fig. 9), which provides the frequency marking, with the special cam disc (OD 0065) delivered with the B.F.O. a partial blocking of the frequency range can be obtained. (Refer also part Description).

I. The replacement procedure is as follows (refer Fig. 9):

1. Disconnect the instrument from the power supply line.
2. Remove the perforated back plate of the cabinet.
3. Carefully remove the steel ball clutch contact from behind the clutch contact spring at "A" by pulling the contact spring gently outwards for a few millimeters ($\frac{1}{8}$ "") to release the contact pressure on the ball which should be placed, after removal, in a small receptacle for safe retention.
4. Set the clutch switch on the front panel to the "Clutch On" position.
5. Unscrew the three screws marked "B" in Fig. 9, taking the precaution that the small spiral springs are retained as with the ball. Remove the now free metal retaining plate "C". When removing this

plate, pass it carefully between the contact spring at "A" and the insulated bushing assembly "D".

6. Likewise remove the outer insulated cam ring "E", which will now be loose, in the same manner as the metal retaining plate. The remaining insulated cam ring should not be removed.
7. Install the cam ring to be fitted, making sure that the white spot on the surface near the slot on the periphery faces outwards towards the operator.

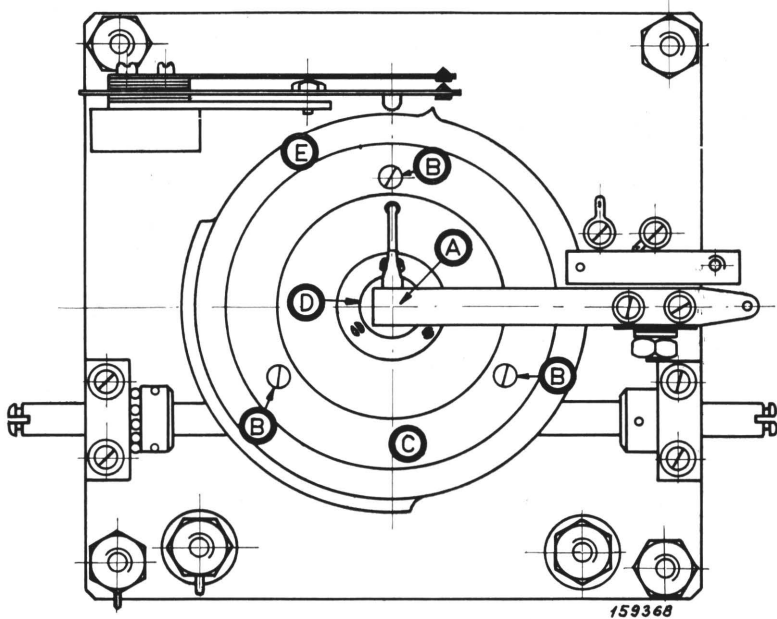

Fig. 9. Cam disc arrangement. For explanation of letters, refer to text.

8. Replace the metal retaining plate, and the three screws together with the three spiral springs, making sure that the screws are properly tightened.
 9. Replace the steel ball.
 10. Replace the perforated back plate to the cabinet.
- II. Adjustment of blocking range.
1. Set "Clutch" control to position "Marking Adjustment".
 2. Turn main frequency scale pointer until a small "click" is heard, the click is associated with an increased effort in turning the pointer.

3. Set pointer to:
 - a. The frequency at which the blocking should be cancelled, if blocking of the initial scale part is wanted.
 - b. Two decades higher, approximately, (will be outside the scale graduation), at which the blocking should commence, if blocking of the last part of the scale is wanted.Check for proper commence of blocking. If necessary readjust as in item b.
4. Release "Clutch" control from position "Marking Adjustment", reverting to position "Off" or "On" as required.
The B.F.O. is now operable as in B, C, D or E.

H. Automatic Regulation of the Output Power.

By means of the compressor circuit it is possible to regulate the output from the oscillator. When a constant output voltage is required, the output voltage from the Oscillator is used as a control voltage. A constant current is obtainable if the voltage drop across a resistor connected in series with the load, is used as the control voltage, and a constant sound pressure is maintainable with the aid of a regulating microphone. The microphone is then placed in the sound field from a loudspeaker which is driven by the Oscillator, and the microphone output voltage used as control voltage. (It is essential that the frequency characteristic of the microphone is linear).

Proceed as follows:—

1. Calibrate the Oscillator as described under Calibration, see under A.
2. Set the "Matching Impedance" switch in the desired position.
3. Connect the load to "Load" terminals or to the screened output socket on the top of the instrument, see B or C.
4. Feed the control voltage to the "Compressor Input" terminal. If necessary use an amplifier which has a linear frequency characteristic for the amplification of the control signal, approximately 1 volt being required for full utilization of the compressor.
5. Set "Compressor Voltage" and "Output Voltage" to maximum (fully clockwise).
6. Feed the voltage to be measured to the recording instrument, e.g. the Level Recorder Type 2305.
7. Set the "Compressor Speed" switch in one of the positions: 30, 100, 300 or 1000 db/sec.
8. Regulate the desired output voltage by turning "Compressor Voltage" knob counterclockwise.

Note: When the Beat Frequency Oscillator is used in conjunction with the Level Recorder Type 2305 the writing speed of the Level Recorder should be kept below the regulation speed of the compressor.

It is also possible to obtain different regulation characteristics dependent on the position of the potentiometer marked "Output Voltage". This can be seen from Fig. 2.

Remote Control.

In the main description of the apparatus several forms of remote control are mentioned. To carry out any one of these methods use must be made of the "Remote Control" jack on the front panel, the appropriate connections being made to the pins of the six-poled socket. Fig. 10 shows the different pins on the socket.

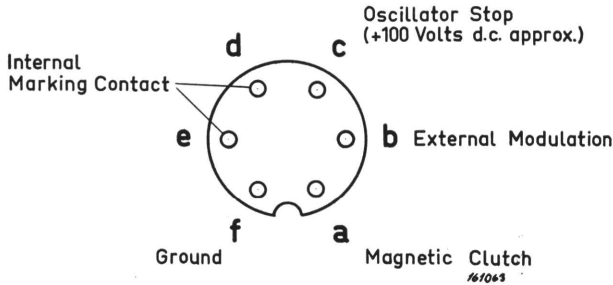

Fig. 10. "Remote Control" jack, viewed looking towards front panel.

Remote control of the magnetic clutch can be obtained by setting or breaking a connection between a and f, providing the clutch control switch is at the position "Clutch Off".

For external modulation it is necessary to connect the external generator between chassis and terminal b, having the "Modulation Frequency" switch set to any position except "Mod. Off."

For remote interruption of the output signal (stopping of the fixed oscillator) the terminal c should be connected to terminal f (ground). This arrangement is used, for instance, when reverberation measurements are carried out automatically by employing the B & K Level Recorder Type 2305. A special switch in the Recorder then connects terminal c to ground when the radiated signal has to be interrupted.

Terminals d and e are in connection with an internal contact used for marking a certain frequency within the Oscillator's frequency range and further to interrupt the signal output when the frequency scale pointer is outside the scale.

Note: When delivered from the factory, each B.F.O. is supplied with a 6-poled plug containing the necessary connections for the function of the internal contact.

Trouble Shooting.

If the B. F. O. is not working properly when switched on, check the following:—

1. That 6-poled plug for the "Remote Control" jack is in position.

2. That scale-pointer is not situated in the uncalibrated section of the main dial, i.e. between 20000 c/s and 20 c/s.
3. That scale-pointer is not on the "marked" frequency or on a section chosen for "partial blocking of frequency range", see pages 9 and 10.

Accessories

Output Transformer TU 0005.

This transformer is designed to allow symmetrical output from the attenuator output of the B.F.O. 1014. (Symmetry better than 0.1 %). The output impedance is 600 Ω and the distortion 0.5 % at 20 c/s with maximum output voltage from the B.F.O. (12.5 V). The accuracy of the Transformer is ± 0.2 db in the frequency range 10 c/s to 35 kc/s. In addition a core material has been chosen for the transformer, which makes it possible to "preload" the secondary winding with a current of 100 mA without causing additional distortion for frequencies above 300 c/s. The transformer ratio is $\sqrt{10} : 1$.

Applications

The field for use of the Beat Frequency Oscillator Type 1014 is so extensive that only a few of the possible applications are illustrated in the following pages, these being classified into three sections, showing the instrument being used as a power source for:—

- (A) Electronic Measurements
- (B) Acoustical Measurements
- (C) Mechanical Measurements.

GROUP A. ELECTRONIC MEASUREMENTS

Measurement of Frequency Response of Four-Terminal Networks.

The object to be tested, e.g. a filter, transmission line, transformer etc. is fed from the Beat Frequency Oscillator Type 1014 output. Then point-by-point measurements can be taken by means of the Audio Frequency Voltmeter Type 2409 (or 2410) or Microphone Amplifier Type 2603 or 2604.

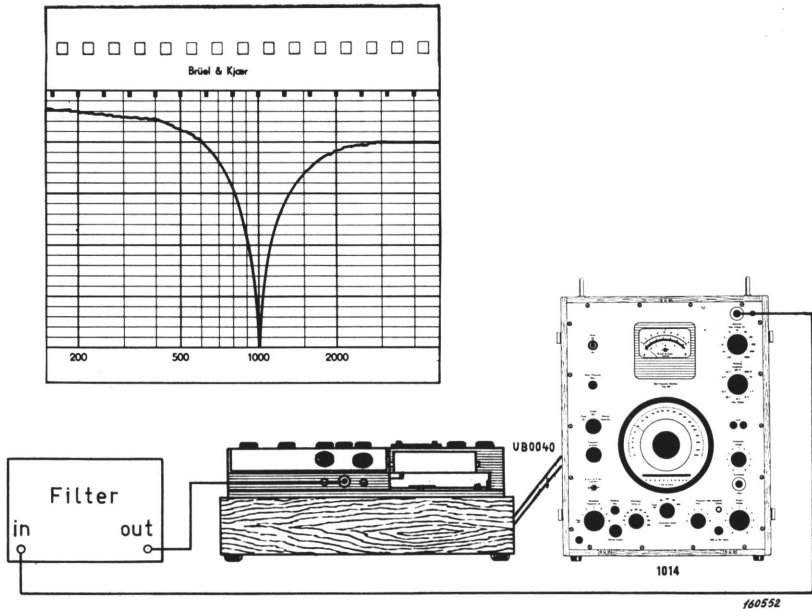

Fig. 11. Measurement of frequency response of four-terminal A.F. network.

If an automatic recording of the frequency response is wanted, the Level Recorder Type 2305 should be used. The mechanical coupling between the motor in the Level Recorder and the tuning capacitor of the B.F.O. is effected with a Flexible Shaft UB 0040 which is delivered with the B.F.O.

The measuring arrangement which is employed to obtain the frequency characteristic of an A.F.-filter is shown in Fig. 11.

Should the compressor circuit be used to regulate the output signal from the Oscillator it is advisable to verify that the voltage at the "Compressor Input" is approximately the required 1 volt. When it is intended to use the equipment for automatic recording of frequency characteristics, the input of the Level Recorder may first be connected to the input of the compressor, and a recording of the compressor input voltage made for the complete frequency range in which measurements are to be taken. With the compressor working correctly the resultant recording should be a straight line. If this is the case the input to the Level Recorder can then be disconnected, and the desired measurements carried out.

A.C. Bridge Measurements.

By employing the B.F.O. Type 1014 and a Frequency Analyzer Type 2107 as an indicating instrument selective measurements of components in an A.C. bridge can be obtained.

The only requirement the bridge must satisfy is that one diagonal point can be grounded as shown in Fig. 12. This requires the bridge to be supplied from the B.F.O. via a screened transformer e.g. TU 0005, the B.F.O. being grounded at one terminal.

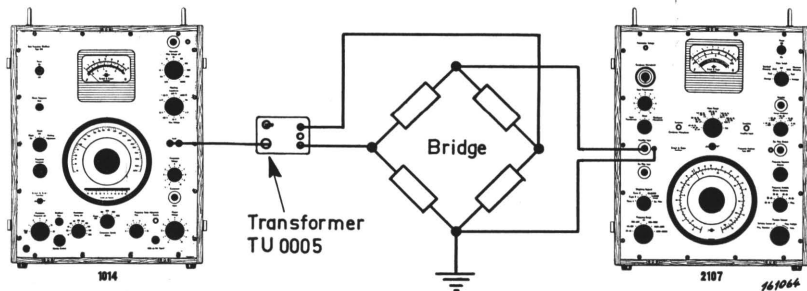

Fig. 12. The B.F.O. Type 1014 used as voltage source for AC Bridge Measurements. The Output Transformer TU 0005 provides a symmetrical output from the B.F.O.

The balancing transformer TU 0005 contains two precision resistors and serves as one half of the bridge circuit. A total output impedance from the transformer of 600Ω is obtained, and the balance between the two trans-

former "arms" is better than 0.1 %. The voltage transmission loss of the transformer when loaded by 600Ω is approximately 16 db and the distortion less than 1 % for a transformer input voltage of approximately 12 V. Due to the selectivity of the Frequency Analyzer it is well-suited as an indicating instrument in a bridge circuit. The decibel scale on the instrument meter will often prove useful when it is desired to measure the quality of different components placed within the bridge.

Measurement of Temperatures and Temperature Differences.

Electrical measurements and recordings of temperatures and temperature variations can be carried out by using the combined BFO Type 1014 and Level Recorder Type 2305 i.e. the Automatic Frequency Response Recorder Type 3304 (see Fig. 13), in conjunction with Negative Temperature Coefficient (N. T. C.) resistors.

A practical example of this is shown in Fig. 14a where the temperatures on both sides of a wall are being measured "simultaneously" by the equipment, allowing the heat loss or insulation value of the wall to be calculated. This joint recording is possible by use of the two-channel selector which is incorporated in the recorder section of the Type 3304.

To make accurate temperature measurements by means of thermistors the following method should be adopted:—

1. The signal voltage must be constant, this being obtained by using the compressor circuit.



Fig. 13. Automatic Frequency Response Recorder Type 3304.

- The current has to be determined by measuring the voltage drop across a fixed resistor which is connected in series with the respective thermistor (see sketch 14a). The obtained voltages are fed to the two input terminals of the above mentioned selector in the Level Recorder section of the Type 3304.

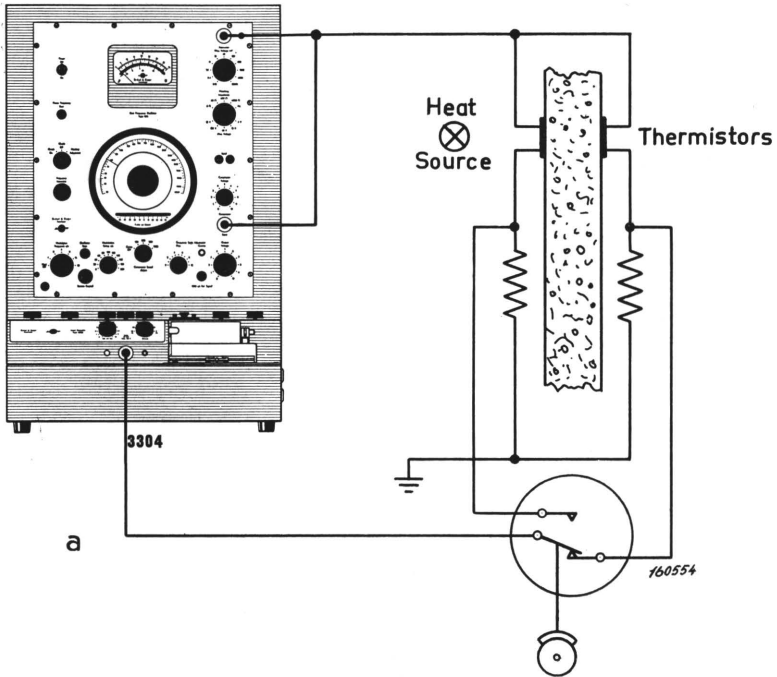

Fig. 14. Measurement of temperatures on both sides of a concrete wall.
(a) Measuring arrangement.

- Prior to the final measurements the set-up must be calibrated, this being done by placing the thermistors in a bath of warm oil the temperature of which has been taken with an ordinary thermometer. During the cooling period the voltage drop across each resistor is taken at requisite intervals and plotted on the side of the paper to be used. As the thermistors have a negative temperature co-efficient a decrease in temperature will cause the voltage drop across the fixed resistor to fall as can be seen on the calibrated curve in Fig. 14b. Fig. 14c shows the recordings of a "simultaneous" measurement taken with the arrangement as in 14a. The wall having firstly been warmed on one side by a constant heat source to the desired temperature, then re-

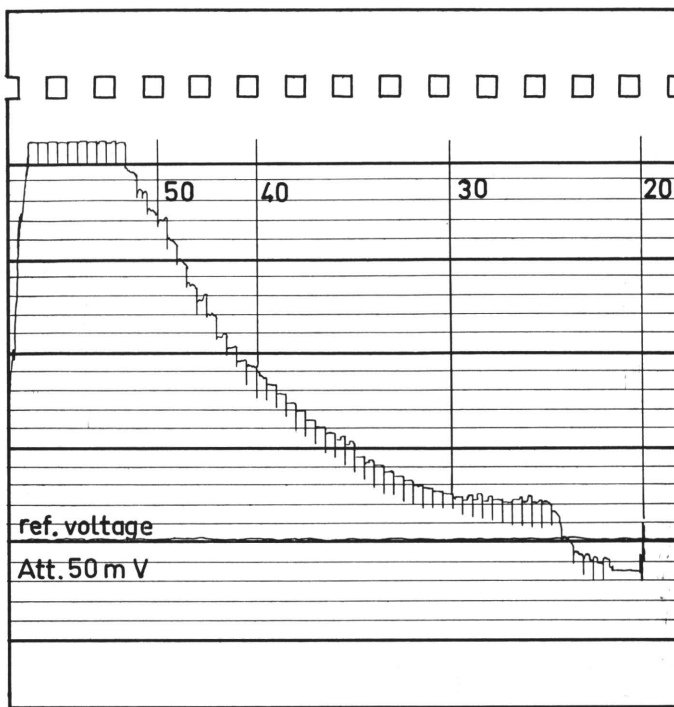

Fig. 14 (b) Calibration Curve.

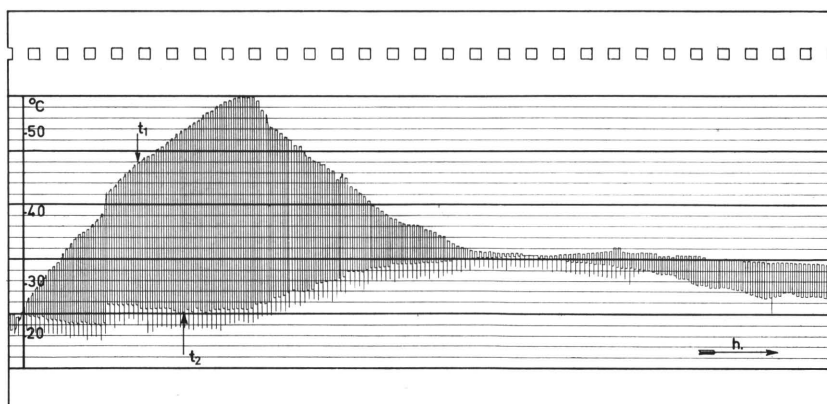

Fig. 14 (c) Simultaneous recording of the temperature on both sides of the wall.

moving the source whereby the temperature gradually falls on the heated surface but still rises on the other surface due to the "inertion" of the heat transmission through the structure, see Fig. 14c.

Measurement of Gain in A.F. Amplifiers.

The measurement of distortion and frequency response of A.F. amplifiers may be carried out in the same manner as for four-terminal networks, the description for the arrangement being given in the initial paragraph to this section.

Frequently it is important to determine the linearity of an amplifier i.e. to measure the gain for different values of input voltage. As the attenuator circuit of the Beat Frequency Oscillator Type 1014 is very accurately calibrated it is an extremely useful instrument in carrying out gain measurements.

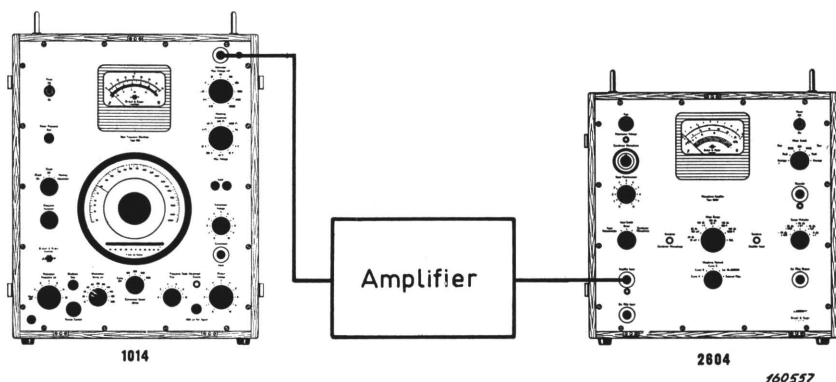

Fig. 15. Measurement of gain in an A.F. amplifier.

The output voltage from the amplifier under test should be measured with an Audio Frequency Voltmeter Type 2409 (or 2410), or a Microphone Amplifier Type 2603 (or Type 2604) an example of the arrangement being given in Fig. 15.

GROUP B. ACOUSTICAL MEASUREMENTS

Frequency Response Recording of Loudspeakers.

Loudspeaker tests may be carried out either in an anechoic chamber, or in the open air. In the open air, noise is generally present, and a completely sound absorbent room should preferably be used.

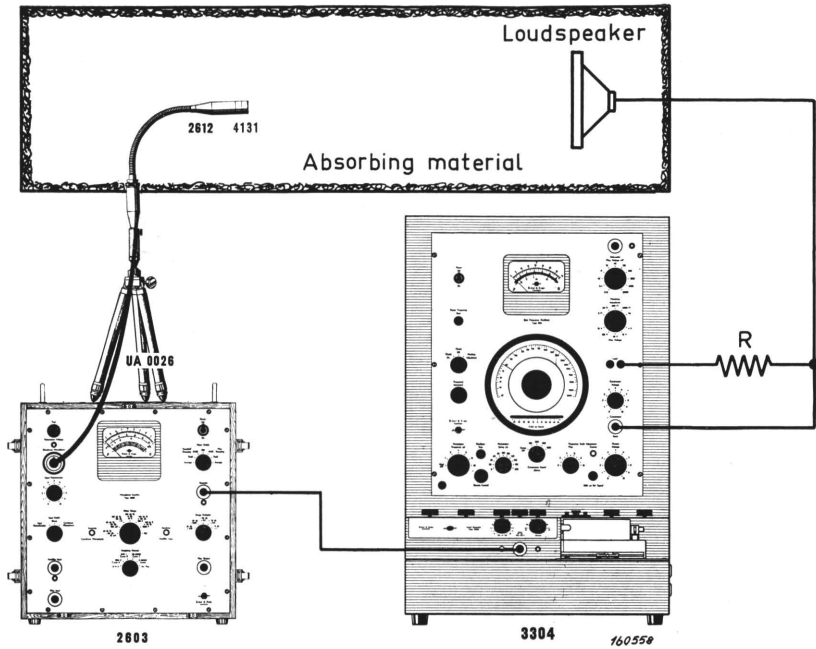

Fig. 16a. Measuring arrangement used for recording the frequency characteristic of a loudspeaker.

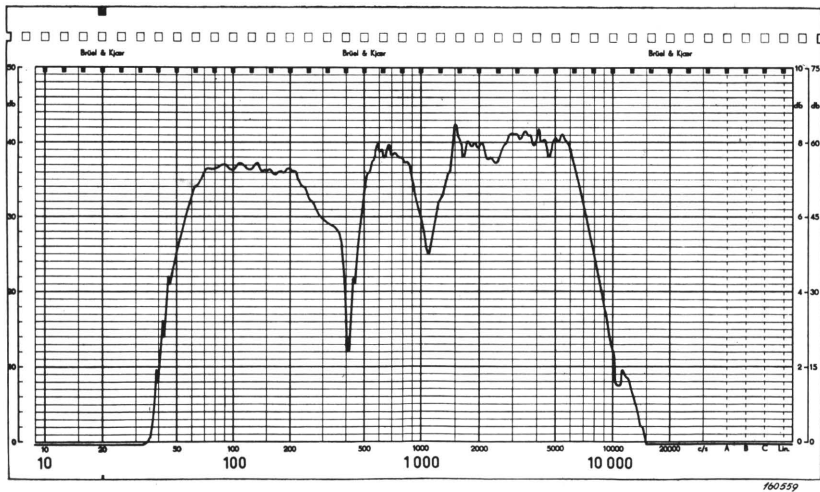

Fig. 16b. Recording of the frequency characteristic of a loudspeaker mounted in a cabinet. (The measurement was not carried out in a completely dead room, and the effect of reflections can be seen from the recording).

The loudspeaker under test should be fed with a constant voltage or current, the latter producing a mechanical force of constant amplitude which is applied to the diaphragm.

Fig. 16a shows a set-up for recording the frequency characteristic of a loudspeaker. The loudspeaker is fed from the B.F.O. section of the Automatic Frequency Response Recorder Type 3304 via a series resistor the voltage drop across which is led to the Compressor Input of the B.F.O. A constant current will therefore be obtained in the circuit when the voltage across the resistor is approximately 1 volt.

The output voltage from the Condenser Microphone Type 4131 is fed to the Level Recorder in the Automatic Frequency Response Recorder via an Amplifier. This amplifier can be a Microphone Amplifier Type 2603 (or 2604) or a Frequency Analyzer Type 2107 or 2112. The Amplifier should be switched to have a linear frequency characteristic.

An advantage gained by employing a Frequency Analyzer as an amplifier is that distortion measurements can be carried out with the same measuring set-up. Fig. 16b shows a recording obtained with the described set-up.

Recording of the Frequency Response of Microphones.

Fig. 17a shows a typical arrangement for automatically recording the frequency response of a microphone.

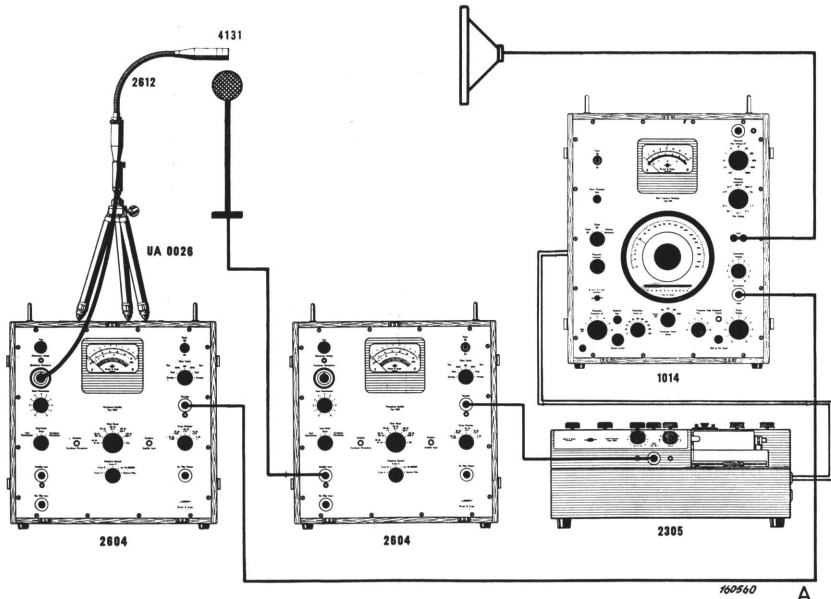

Fig. 17a. Measuring set-up for automatic recording of the frequency response of microphones.

In the set-up depicted, the microphone to be tested is connected to the Level Recorder Type 2305, via a Microphone Amplifier Type 2604, the originating sound source being a loudspeaker which is fed from the B. F. O. Type 1014. As the sound pressure in front of the microphone under test has to be kept constant, it is necessary to place it relatively close to another microphone (in this case a Condenser Microphone Type 4131) which is coupled to a second Microphone Amplifier Type 2604, the output of which is fed to the "Compressor Input" of the BFO ensuring a constant sound source. It is essential that the two microphones are symmetrically placed in the radiated sound field and the correct compressor speed selected. If the acoustical delay time required for the sound to travel from the loudspeaker to the microphone is τ , this period must be small in comparison to the time constant determining the compressor speed. Under normal circumstances these conditions are easily fulfilled.

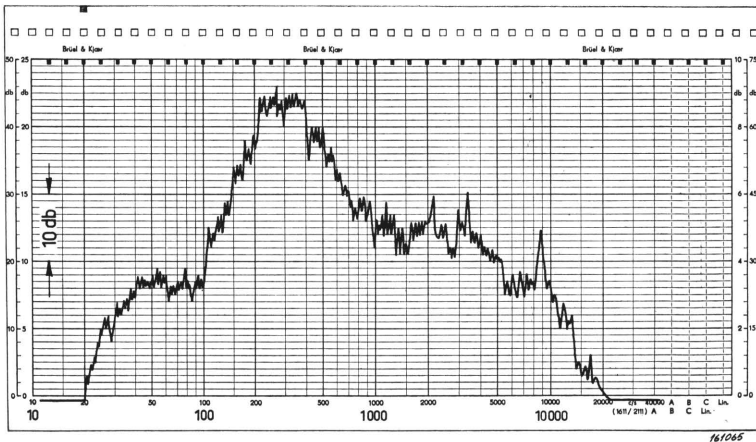

Fig. 17b. Recording made with the set-up shown in 17a.

To give reliable measurements the room to be used need not be fully anechoic as the regulating effect of the compressor will compensate for any minor reflections set-up. However, for correct operation of the regulation circuit, the reverberation time of the room must not be too long and a low scanning speed should be used for the frequency sweep.

In Fig. 17b will be seen a recording showing the frequency response of a microphone recorded by employing the previously outlined system.

Recording the Frequency Characteristic of Hearing Aids and Earphones.

A recommended set-up for the testing of the above units is displayed in Fig. 18a. By this method it is possible to automatically record the frequency characteristics of the components under well-defined acoustical conditions.

The B.F.O. 1014 feeds the earphone under test which is placed in the Artificial Ear Type 4151. The ear consists basically of a base mounted on a board and a replaceable acoustical coupler. Different types of couplers are available. A DB 0138 2 cm³ which conforms to ASA Z 24. 9. 1949 and the new IEC standards is suitable for measurements on insert type of earphones. For headsets and similar external earphones a 6 cm³ can be supplied e.g. DB 0160 (N. B. S. type) or DB 0161 (A. S. A. type).

(a)

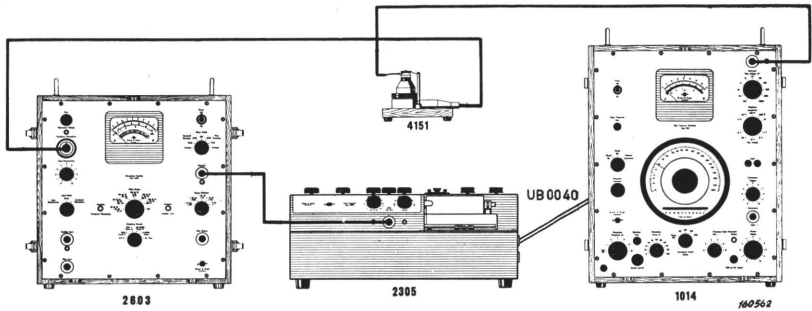

(b)

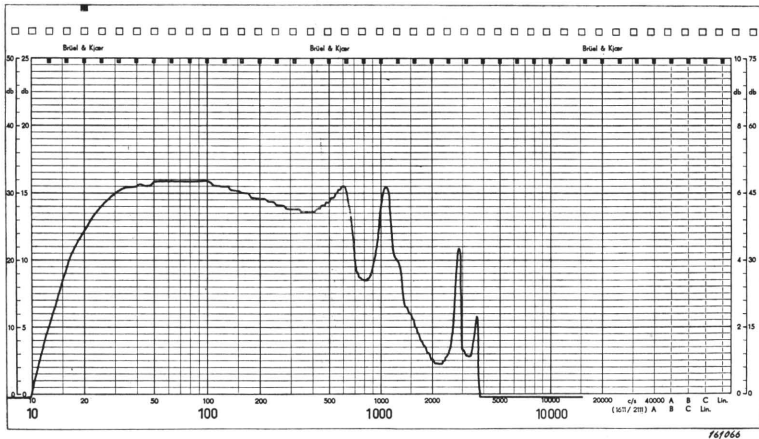

Fig. 18.

(a) Measuring arrangement.

(b) Recording of the frequency characteristic of an earphone.

A B&K Condenser Microphone 4132 is placed in the coupler and measures the S.P. L. produced by the earphone. The output from the Microphone is fed to the input of the Amplifier Type 2603 and the amplified signal led to a Level Recorder Type 2305 to obtain a graphic recording, see also Fig. 18b.

Checking of Hearing Aids.

An arrangement for the checking of Hearing Aids is illustrated in Fig. 19a. This set-up makes it possible to automatically record the frequency characteristic of a complete hearing aid, under what are approximately free field conditions.

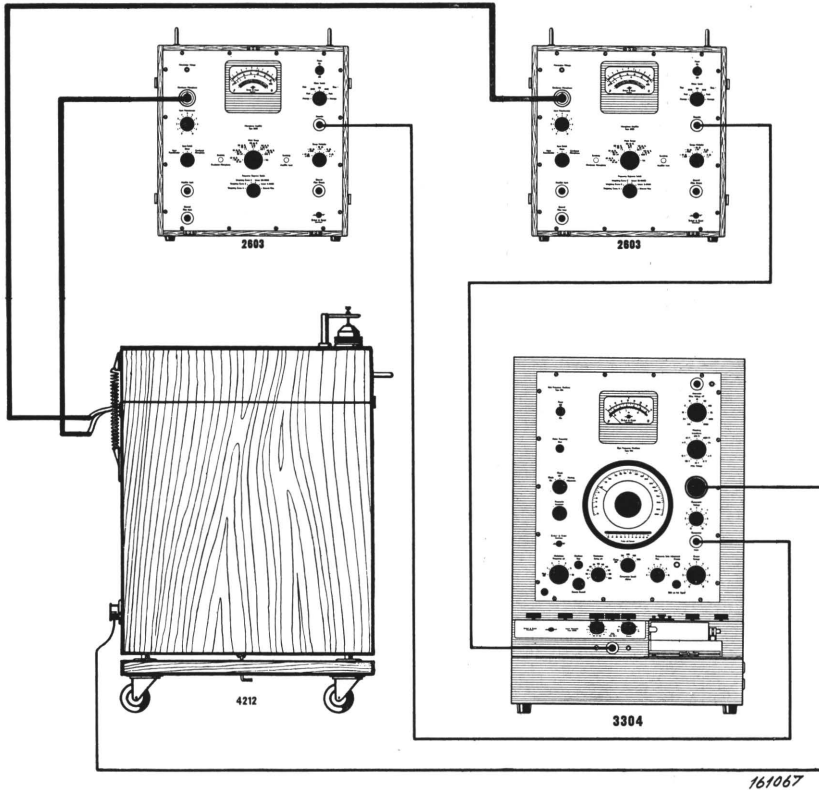

Fig. 19.

(a) Arrangement for automatically checking the frequency characteristic of a hearing aid.

The hearing aid earphone under examination is placed on the ear of the Hearing Aid Test Box Type 4212, which consists of an external artificial ear, a regulating microphone, a built-in loudspeaker, the latter two of which are enclosed in a small anechoic chamber. The chamber is effectively insulated against both airborne and impact noise, allowing measurements to be taken down to 50 db re 2×10^{-4} μ bar approximately.

The hearing aid and the regulating microphone are placed symmetrically in the sound field. The regulating microphone is connected to the Microphone Amplifier Type 2603, which amplifies the signal and then applies it to the Compressor input of the B.F.O. Type 1014. This combination enables the sound pressure level on the hearing aid to be kept constant without influencing the practically free sound field conditions.

The B. F. O. Type 1014 supplies the required power for the loudspeaker in the chamber, while a B & K Condenser Microphone, which is placed in the Artificial Ear, is used for the measurement of the acoustic output from the hearing aid. The microphone is connected to a Microphone Amplifier Type 2603, and the amplified voltage is led to the input of a Level Recorder Type 2305.

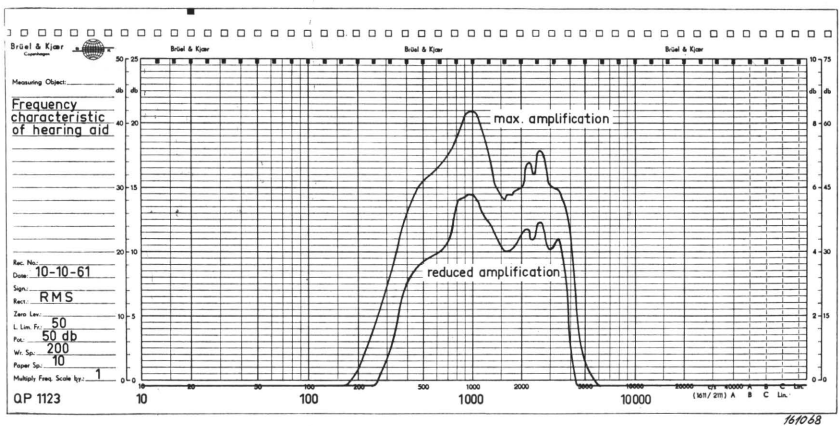

Fig. 19. (b) Recording by 19 (a). Taken for different settings of the hearing aid volume control.

Fig. 19b shows typical characteristics of a hearing aid device automatically recorded with the arrangement described in 19a. (N.B. Recordings are taken for two different settings of the hearing aid volume control).

Measurements on Air Filters, Carburettor Inlets, etc.

To carry out measurements on the above and other such items as mufflers, silencers, etc. it is necessary to provide a high but constant sound level source. This can be readily obtained by using the Constant Sound Pressure Source Type 4211 in conjunction with the B. F. O. 1014. The B. F. O. 1014 gives high regulation of the signal (by the use of the compressor circuit), even when operating at maximum rated power.

An arrangement utilising the Type 4211 in conjunction with the combined B. F. O. 1014/Level Recorder 2305, (i. e. Automatic Frequency Response

Recorder Type 3304) is shown in Fig. 20, the item under test being an air filter. Fig. 21 shows the resultant curves which give an indication of the attenuation of sound waves in the air filter. Curve A is measured with the Sound Pressure Source 4211 open and Curve B with the filter mounted on the Source opening. The sound pressure level at the air filter input in both cases being 110 db with reference to $2 \times 10^{-4} \mu\text{bar}$, and to avoid directional influences the measurements were carried out in a highly reflective hard-walled chamber.

In many instances there will be a requirement to find the most suitable position to mount absorbent material in order to silence the object on test. When this situation arises measurements should be carried out under "free

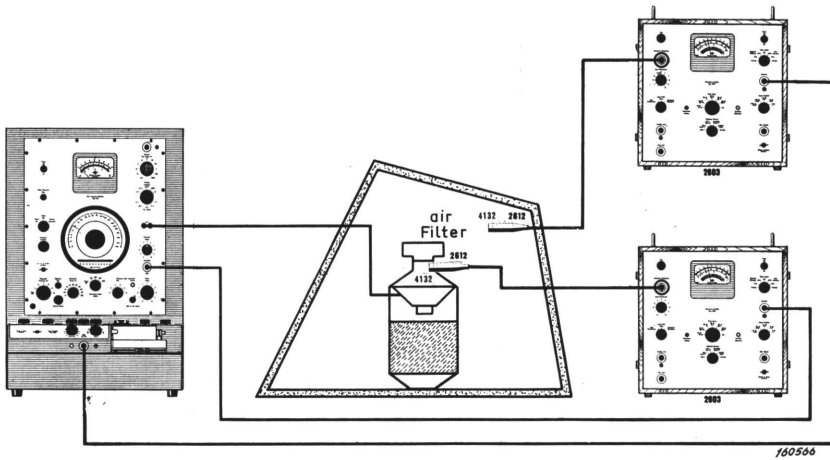

Fig. 20. Arrangement for determining the sound attenuation in an air filter.

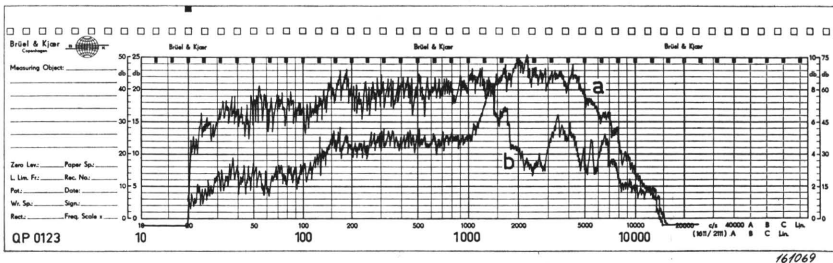

Fig. 21. Determination of the air filter's sound attenuation.
 Curve (a) Measurement without air filter.
 Curve (b) Measurements with air filter mounted on top of the Constant Sound Pressure Source 4211.

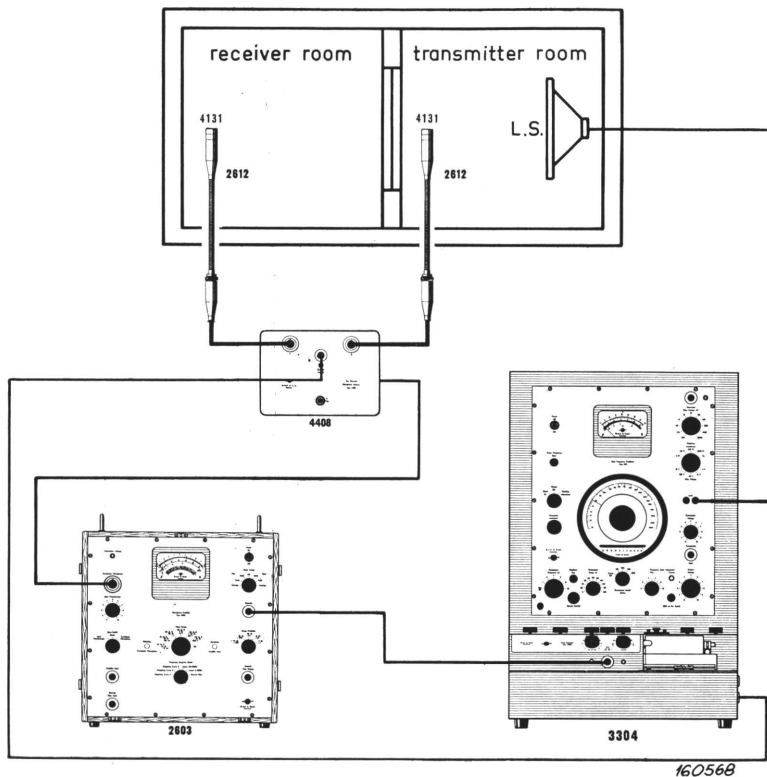

Fig. 22.

(a) Measuring arrangement for automatic reading of the sound insulation properties of a wall.

field conditions” or in an anechoic chamber allowing the directional pattern of the unit under examination to be obtained.

Testing the Qualities of Airborne Sound Insulation.

A means of automatically carrying out these test is shown in Fig. 22a. The wall under test is placed between two rooms, which are termed “the transmitting room” and “the receiving room” respectively.

In each of the two rooms separated by the wall is placed a Type 4131 microphone individually coupled to a Cathode Follower Type 2612. Two extension cables connect the microphone units with the Two-Channel Microphone Selector Type 4408. The Microphone Selector is remotely controlled by the two-channel switching device, which is “built-in” to the Level Recorder portion of the Automatic Frequency Response Recorder Type 3304. In this case the Recorder is using a 50 db Range Potentiometer and the

necessary sound is generated by the BFO 1014 section of the Type 3304 in conjunction with a loudspeaker. The Beat Frequency Oscillator should be frequency modulated and the loudspeaker (or loudspeakers) placed so that a sound field, as diffuse and isotropic as possible, is built up.

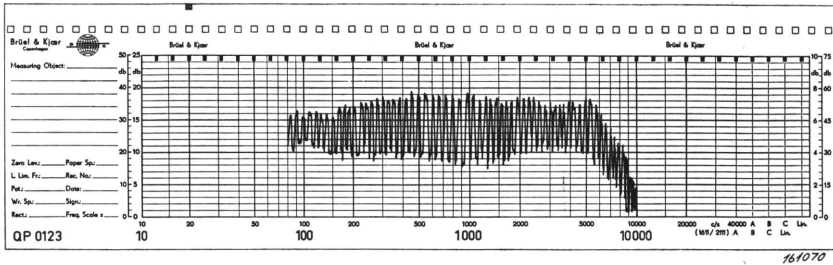

Fig. 22 (b) Recording obtained with a measuring set-up as in (a).
N.B. 50 db Range Potentiometer is used in Level Recorder.

By means of the Microphone Selector which is connected to the Microphone Amplifier Type 2603, the different sound levels picked up in the two rooms are taken alternately and amplified before being fed to the Level Recorder. The result is that two independent curves are automatically reproduced on the recording paper, enabling the sound level difference between the two sides of the wall to be read off in decibels. The sound absorption of the receiving room must be taken into account.

Measurement of Reverberation Time.

One of the more important factors in determining the acoustic qualities of a room is the measurement of the room's reverberation time. The Beat Frequency Oscillator includes special functions, such as the compressor

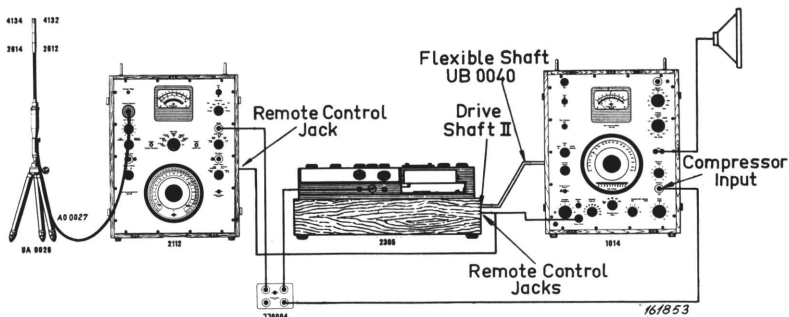

Fig. 23. Measuring equipment for the automatic recording of reverberation time. Compressor of the B. F. O. employed.

circuit and the possibility of frequency modulation, which makes it very suitable for this type of measurement. The compressor circuit serves to keep the sound radiated in the room at a constant value throughout the frequency range of the measurements. Frequency modulation of the signal radiated in the room ensures that a great number of eigentones of the room are excited in the frequency band covered by the frequency modulated signal. The resultant recorded decay curves will in this manner appear with a smooth slope. That would not be the case when a pure sine-wave signal is radiated in the room, as distinct standing waves would arise. The frequency modulation is easily adjusted in frequency swing and modulation frequency by the controls "Modulation Swing" and "Modulation Frequency" respectively.

Various measuring arrangements for reverberation measurements can be set up where the B.F.O. is an integrating part. Here will be discussed an arrangement which works automatically and where the measured decays are recorded by the B & K Level Recorder Type 2305. The set-up is illustrated in Fig. 23. The B.F.O. Type 1014 and the loudspeaker constitute the transmitting part, whereas one of the B & K Condenser Microphones, the Audio Frequency Spectrometer Type 2112 and the Level Recorder Type 2305 make

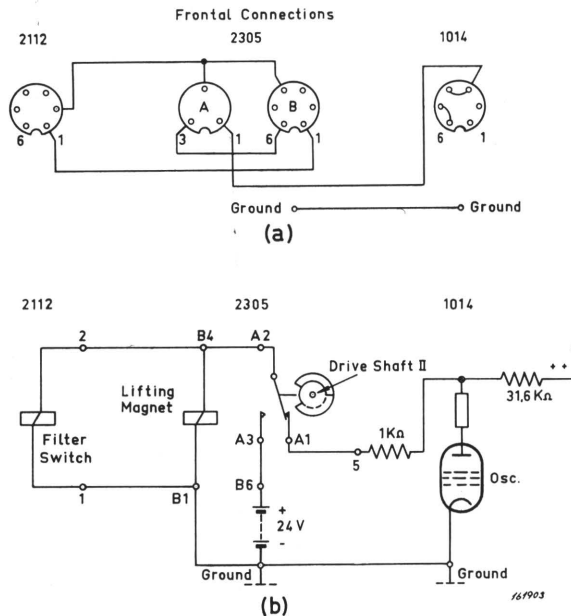

Fig. 24. Connection between instruments.
 (a) Connections between remote control jacks.
 (b) Electrical circuit of the remote arrangement.

up the receiving part. As the amplifier for the Microphone is chosen the Spectrometer which makes a selective reception in $\frac{1}{3}$ or $\frac{1}{1}$ octave bands possible, thereby reducing the influence of the room's background noise. A sufficient dynamic range is in this manner obtained when measurements are carried out in rooms where the background noise cannot be removed. The measuring arrangement shown allows decay curves of the reverberation to be recorded automatically throughout the frequency range 25 c/s to 20000 c/s with intervals of $\frac{1}{3}$ octave. All the decays are registered on a frequency calibrated part of recording paper being only 250 mm in length (refer Fig. 26). If greater spacing between the individual decay curves is required, the recording has to be made on non-frequency calibrated paper. Below is given a brief description of the principal working of the two types of measurements.

Frequency Calibrated Paper. For recording the decay of the sound in the room the sound source has to be disconnected at definite intervals, this is achieved by stopping the oscillator in the B.F.O. To ensure that only the part of the measurement is recorded which is of interest, the writing pen should lift from the paper in the interval between two decays, and as selective reception is utilized, the filters in the Spectrometer should be switched in successively. The disconnecting of the sound source, the lifting of the pen and the switching of the filters in the Spectrometer can all be automatically controlled by a special switch in the Level Recorder. (The Two-Channel Selector). The necessary connections between the different instruments are shown in Fig. 24. The connections to the respective Remote Control Jacks are shown in Fig. 24a, while Fig. 24b gives the electrical circuits for the remote controlling arrangement.

Overlapping junction.

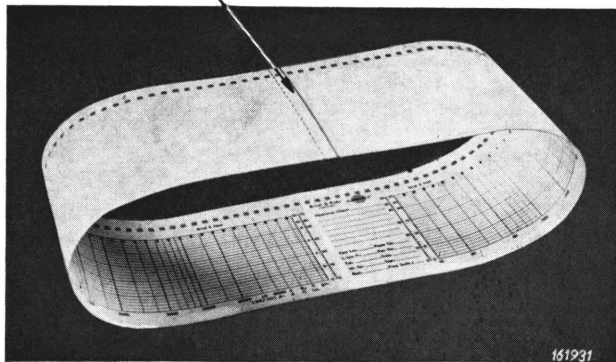

Fig. 25. Making up of paper loop.

When placing a loop of 50 mm paper width (Fig. 25) in the Level Recorder with a length of 495 mm (i.e. two chart lengths minus 5 mm; 5 mm being the distance between two perforated holes) it is possible to have the curves for the different frequencies placed with a spacing of $\frac{1}{3}$ octave as shown in Fig. 26. By cohesively synchronizing the paper movement with the fre-

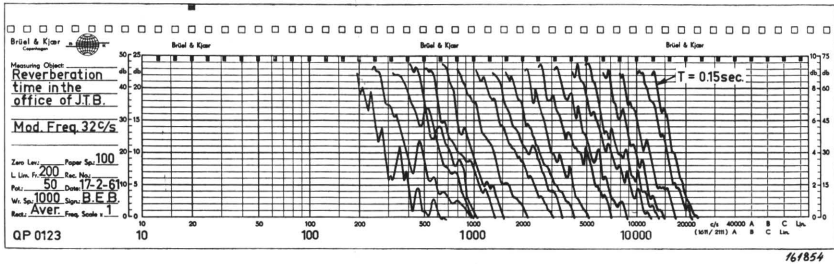

Fig. 26. Example of recording of decay curves. Compressor arrangement used.

quency scanning of the B. F. O., with the filter switching on the Spectrometer and with the switching off moment of the sound, the starting points of the decay curves will correspond to the center frequency of the respective filters, represented by small squares on the top of the preprint of the recording paper QP 0123, QP 0223 and QP 0323, see Fig. 26. It is possible, to a certain degree, to keep the sound pressure level at the point of measurement independent of loudspeaker and room response by utilizing the compressor circuit of the B. F. O. as indicated in Fig. 23. This method ensures that all the decay curves commence at the same level on the recording paper.

Non-Frequency Calibrated Paper. When a larger spacing than 5 mm between the decay curves is desired (vide example in Fig. 27), the recording paper loop used in the Recorder has to be made accordingly shorter as the length of this determines the spacing. For example, a loop length of 490 mm gives

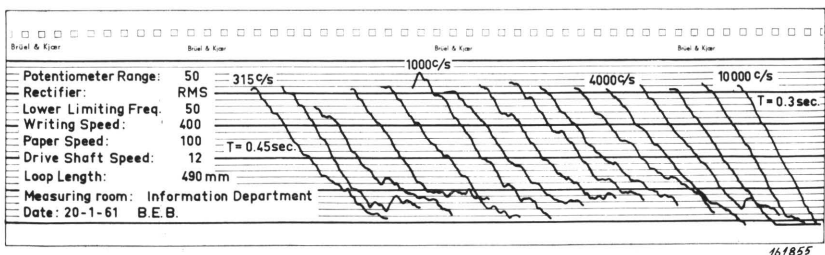

Fig. 27. Decay curves at 10 mm intervals recorded on a loop of 490 mm.

10 mm spacing between the curves. In such instances the recording has to be carried out on the lined recording paper, e.g. QP 0102, QP 0202 or QP 0203, and it is necessary to "mark" one or more frequencies on the paper. The marking can be readily done by means of the Level Recorder's "Event-Marker" arrangement.

If only a few reverberation curves are to be taken, the situation may not warrant the use of automatic measuring, in these circumstances use should be made of the pressbutton marked "Oscillator Stop" on the B. F. O. Also, when it is desired to record the decay curves with a spacing less than $\frac{1}{8}$ octave, the described function of the automatically working arrangement cannot be used immediately. The manually or remotely operated "Oscillator Stop" may then be utilized.

Use of the Protractor SC 2361.

The Protractor has been designed to facilitate the determination of reverberation time from recorded decay curves on the 50 mm width paper. It is divided into four sections marked "75 db 10 mm/sec.", "75 db 30 mm/sec.", "50 db 10 mm/sec.", and "50 db 30 mm/sec.". When one of these four combinations of "Range Potentiometer" and "Paper Speed" has been employed during the measurements, the reverberation time can be read directly in seconds.

1. The Protractor is held so that the printing is readable. The proper section is chosen and its left limiting line (thick diagonal) is placed on top of the portion of the recorded decay curve to be measured, and in such a manner that the centre of the Protractor coincides with one of the horizontal lines on the recording paper. Refer Fig. 28.

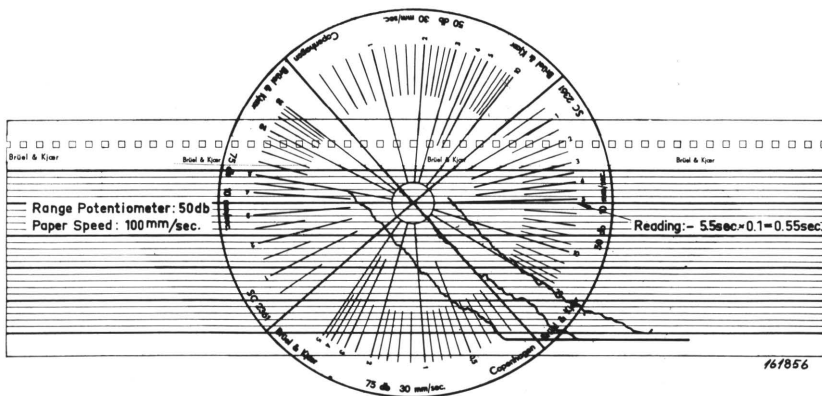

Fig. 28. Use of Protractor SC 2361.
 Ten times higher paper speed used than stated on the protractor section
 "50 db, 10 mm/sec.". Reading then divided by 10, i.e. 0.55 sec.

2. The reverberation time in seconds is then read on the scale at the point through which the horizontal line passes. Vide Fig. 28.

The decay curves should preferably be approximated into a straight line making it easier to determine the average slope.

If paper speeds other than 10 and 30 mm/sec. have been used, the determined reverberation times should be multiplied or divided by factors of 10.

Example.

50 db Range Potentiometer.

Paper Speed 100 mm/sec.: Use the section "50 db 10 mm/sec." and divide the measured result by 10, see also Fig. 28.

Absorption Measurements of Sound Insulation Material.

The B. F. O. Type 1014, in conjunction with the Standing Wave Apparatus Type 4002, enables the sound absorbing properties of different materials to be evaluated and their sound absorbent coefficients to be determined.

A lay-out is shown in Fig. 29, the B. F. O. Type 1014 feeding the loudspeaker which is mounted in the end of the tube of the Standing Wave Apparatus

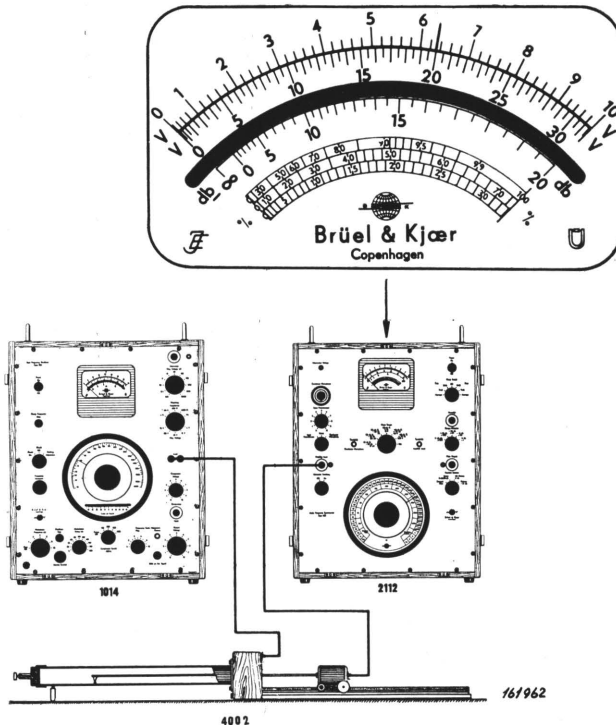

Fig. 29. Absorption measurements on sound insulating material by means of Standing Wave Apparatus Type 4002. Spectrometer Type 2112 and B.F.O. Type 1014.

Type 4002. Included in the apparatus is a probe type microphone which is mounted on a trolley, allowing the open end of the probe to be stationed at any point along the central axis of the tube. The output of the microphone unit is connected to the input of the Frequency Analyzer Type 2107 or the Audio Frequency Spectrometer Type 2112. The Analyzer Type 2107 can be continuously tuned through the band 20 to 20000 c/s with a constant percentage bandwidth, the 3 db bandwidth being variable in steps from 6 % to 29 %. On the other hand the Spectrometer 2112 has $33 \frac{1}{3}$ octave and 11 octave filters with center frequencies from 25 c/s to 40 kc/s, and 31.5 c/s to 31.5 kc/s respectively. Both equipments have meter scales which directly indicate the sound absorption coefficient.

The material to be tested is placed in the termination end of the Standing Wave Apparatus and when the set-up is operated, due to the sound reflection from the sample, standing waves are produced in the tube. If the termination of the tube was made to consist of a totally rigid material, a complete reflection of the sound wave with minima equal to zero would be obtained. On replacing the rigid termination with an absorbent material only part of the wave will be reflected and the minima will no longer be zero. Thus by measuring the ratio between the maximum and minimum sound pressures the absorption co-efficient of the sample for 0 degree incidence sound can be found.

GROUP C. MECHANICAL MEASUREMENTS

Strain Measurements on Vibrated Objects.

In the measuring of mechanical strain on objects under vibration, it is essential that the vibration acceleration is kept constant within the range of frequencies at which measurements are being taken and that inherent resonances in the system have no effect on the magnitude of the driving force.

The illustration in Fig. 30a shows a test rig for strain measurements of small mechanical constructions, the BFO. 1014 section of the Automatic Frequency Response Recorder Type 3304 feeding the shaker, the object under test being placed on the shaker table.

To keep the acceleration constant a controlling system is utilized. This system consists of an Accelerometer Type 4308 mounted on top of the test object. As the acceleration has to be constant and under control the output voltage is connected via a Cathode Follower Adaptor JJ 2612, Cathode Follower 2613, and a Microphone Amplifier 2603 to the compressor input of the B. F. O. The filter switch on the Type 2603 should be set to position "Linear".

By using the built-in meter on the Amplifier Type 2603, the output voltage of the Accelerometer can be observed and the acceleration calculated from

the Accelerometer's sensitivity curve. From this the driving force can be calculated, using Newton's equation $F = m \times a$, where F = the driving force, m = the mass, and a = the acceleration.

To measure the mechanical strain in the object under test a Strain Gage

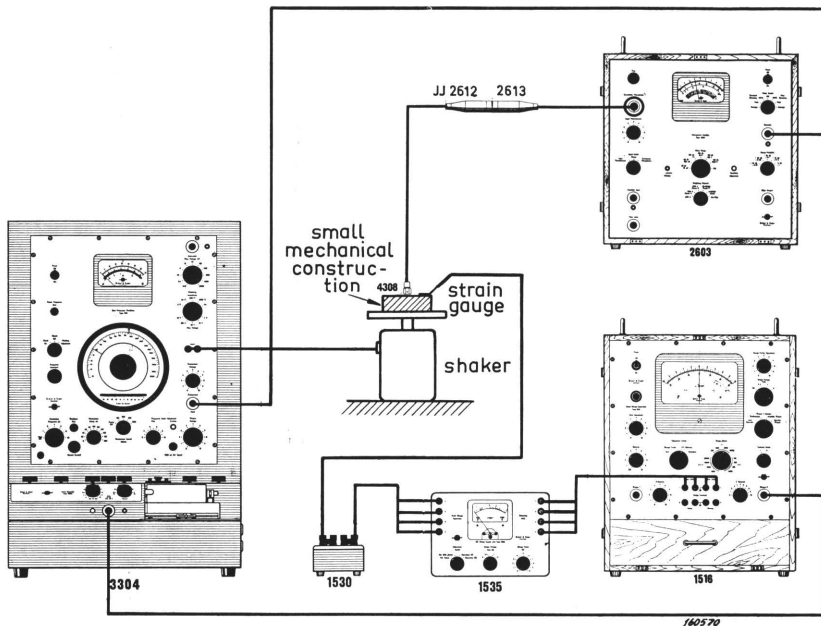

Fig. 30a. Arrangement for measurement of vibrations in small mechanical constructions.

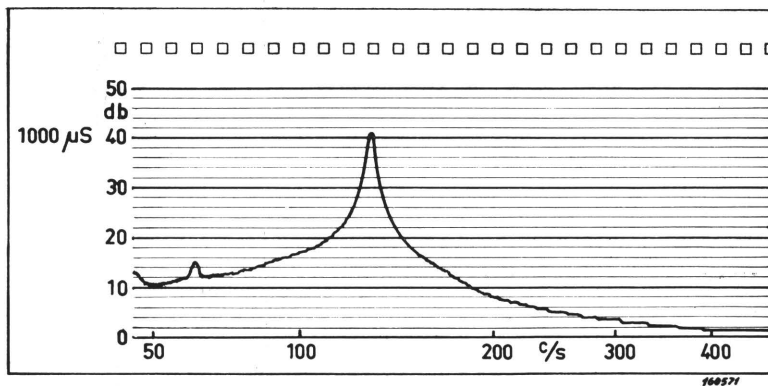

Fig. 30b. Recording of the mechanical strain of a bar. Measured with an arrangement as shown in Fig. 30a.

is used. This is a pick-up device which is comprised of a looped resistance (or resistances) sandwiched between insulating material which is cut in the form of a strip, and which can be glued on to the test object. The object when subjected to mechanical strain is distorted and this will alter the Gage resistance, the variation being registered by a sensitive measuring bridge arrangement, e.g. the Strain Gage Apparatus Type 1516. (For further information refer to manual).

The output voltage from the Strain Gage Apparatus is then fed to the input of the Level Recorder of the Type 3304, to give an automatic recording. An example of such a recording, taken on a thin metal bar, showing the mechanical strain and indicating its resonant frequency, is shown in Fig. 30b.

The A.F. Response and Spectrum Recorder Type 3326.

DESCRIPTION

The apparatus is a combination of the Beat Frequency Oscillator Type 1014, the Audio Frequency Spectrometer Type 2112 and the Level Recorder Type

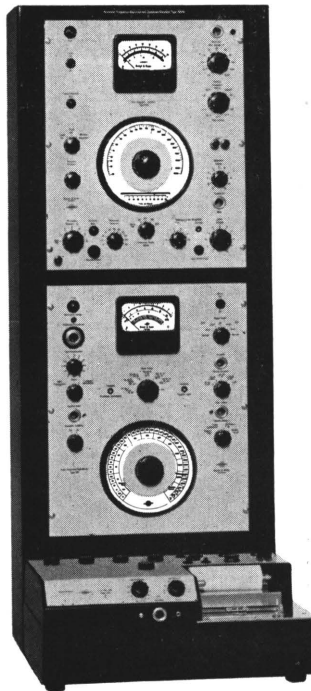

Fig. 31. Photograph of the A.F. Response and Spectrum Recorder Type 3326.

2305, all being housed in one unit. The complete assembly gives a compact means of carrying out and automatically recording almost any desired electrical, electro-acoustical, or acoustical measurement in the audio frequency range.

Fig. 31 shows a photograph of the equipment. For a comprehensive technical description of the Spectrometer and the Level Recorder, reference should be made to their respective manuals. However, a brief outline of their basic principles is given in the following paragraphs.

The Audio Frequency Spectrometer.

The basic design of the Spectrometer is shown in Fig. 32. The input amplifier section consisting of three stages is supplied with a large amount of negative feedback, thus ensuring that a low source impedance (approx. 10 ohms) is coupled to the filter system.

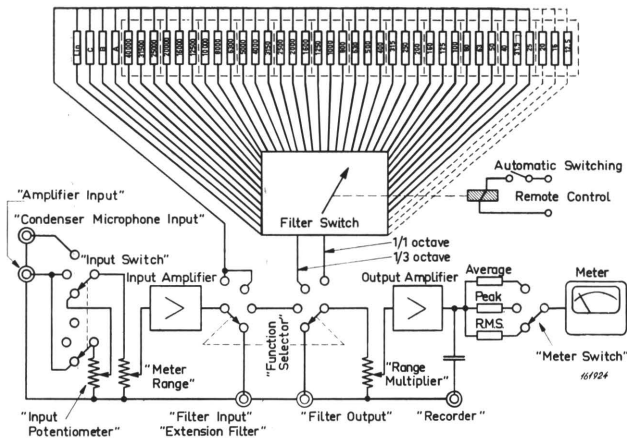

Fig. 32. Block diagram of the Spectrometer.

The filter system is made up of 33 band-pass filters and three weighting networks. The center frequencies of the filters being: 25 — 31.5 — 40 — 50 — 63 — 80 — 100 — 125 — 160 — 200 — 250 — 315 — 400 — 500 — 630 — 800 — 1000 — 1250 — 1600 — 2000 — 2500 — 3150 — 4000 — 5000 — 6300 — 8000 — 10000 — 12500 — 16000 — 20000 — 25000 — 31500 — 40000 when switched for $\frac{1}{3}$ octave analyses, and: 31.5 — 63 — 125 — 250 — 500 — 1000 — 2000 — 4000 — 8000 — 16000 — 31500 in the case of octave analyses. Switching from filter to filter is accomplished by a rotary switch in the output circuit, and a large illuminated scale is used for filter identification. The output amplifier, similar to the input, contains three stages also

supplied with a large amount of negative feedback. The metering circuit connected to the output amplifier can be switched to measure half the peak to peak, average or RMS value of the input signal.

The linear frequency range covered is 2 c/s to 45000 c/s and the three weighting networks conform to the IEC-proposed standards for precision sound level measurements.

The Level Recorder.

The Level Recorder has been designed to record signal levels in the frequency range 10 c/s to 200000 c/s as well as d. c. The operation of the instrument is based on the servo-principle. Fig. 33 shows a block diagram of the instrument.

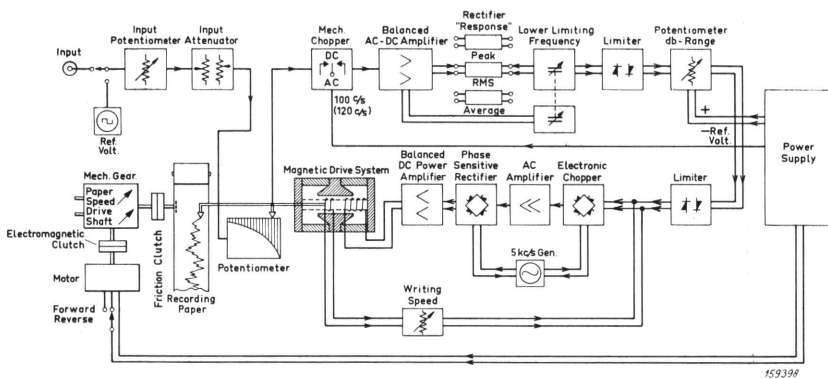

Fig. 33. Block diagram of the Level Recorder.

Fundamentally the Recorder consists of an interchangeable range potentiometer; a direct coupled amplifier; the special B & K rectifier circuit which gives RMS, Average or Peak detection of the input signal, a DC chopper amplifier and an electro-mechanical writing system.

When the magnitude of the voltage applied to the input terminals is changed a current will flow through the driving coil of the writing system thus moving the stylus, which is mechanically coupled to the range potentiometer. By the movement of the stylus the voltage delivered from the potentiometer to the AC amplifier will be altered until a stable condition is regained. In this way it is possible to obtain different ranges of voltage variations which can be recorded, by employing different range potentiometers. Logarithmic range potentiometers are available for voltage level ranges of 10, 25, 50 or 75 db. Two linear potentiometers cover the ranges 10 to 35 mV and 10 to 110 mV respectively.

The recorder is capable of writing on two different widths of recording paper, 50 mm and 100 mm. To change from one width to the other it is

only necessary to release a snap-lock arrangement on the moving arm which holds the stylus.

The writing speed is determined by the amount of damping applied to the writing system which is selectable by the rotary switch "Writing Speed". This is variable in 15 spot settings shown by the figures outside the switch. The large figures denote the settings for 50 mm paper while the small figures are for recordings on paper of 100 mm width.

Recording Paper.

Different types of pre-printed recording paper to be used on the Level Recorder in conjunction with the Beat Frequency Oscillator Type 1014 and Spectrometer Type 2112 combination are available, the paper being manufactured with a printed logarithmic frequency scale covering the range from 10 c/s to 40000 c/s.

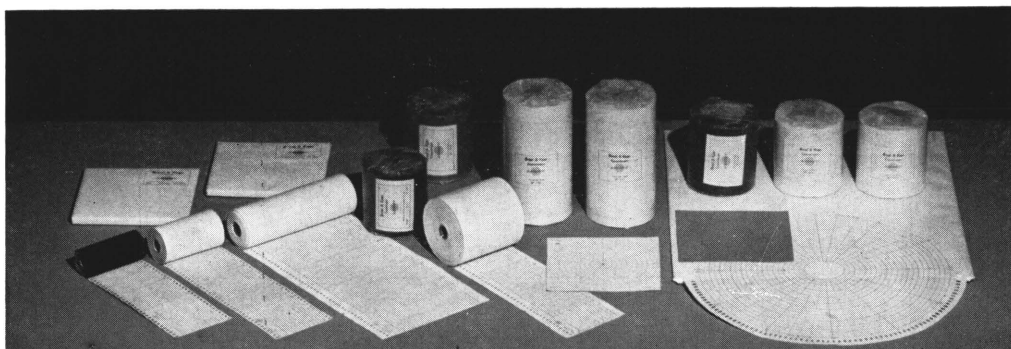

Fig. 34. The various types of pre-printed recording paper.

Three main types of paper, having various features, and which come in two widths, can be supplied. Also included in the range is polar diagram recording paper to be used when the Level Recorder is required for this application (see Level Recorder Manual). Two types of writing are catered for, either ink or stylus, the applicable surfaces being treated accordingly. White paper for ink writing is available, with pre-printed lines or outlines of frequency diagrams and is obtainable in the widths of 100 mm or 50 mm. The polar diagram type comes in packs of 100 sheets and has a 100 mm radius. The waxed paper comes in two types but only in 50 mm widths, i. e. white waxed, or red waxed, and are intended for use with a sapphire stylus. The white waxed paper consists of coated black paper and exhibits printed lines or frequency diagrams as the case may be. The red waxed type is comprised of transparent paper with a thin covering of red wax, having printed lines or frequency diagrams superimposed on it. Waxed paper is particular useful

when high writing speeds have to be used, giving a very clear definition of the recording. When using these papers the sapphire stylus will leave a thin black line on the white waxed paper and a transparent line on the red waxed paper, the latter being specially made to enable blue prints to be taken. It is necessary to double-copy the latter, as the scales being printed in black will not show up if a direct blue print is taken from it.

Copying of Recorded Information.

Curves or data, recorded on the white paper in ink, are ideal for reproduction by photostatic copying or blue printing. The frequency range lines are outlined in orange, making it very suitable for photostatic copying. To allow good blue printing or other methods where light is passed through the paper, the lines of the frequency diagram are impenetrable to light. To give clear curves on the prints, it is preferable to use black ink in the pen.

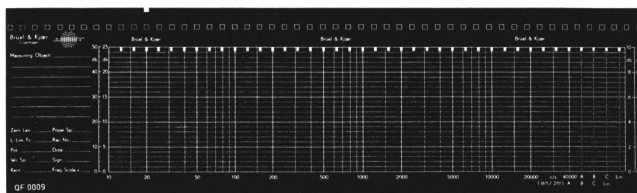

Fig. 35. Photo of Photographic Negative QF 0009 with transparency frequency diagram.

When it is desired to make copies of data recorded on the transparent, red-waxed paper, the use of a Photographic Negative QF 0009 and a double-copying process is necessary.

The recommended method to “double-copy” is as follows:—

1. Fasten the recorded paper strip at the left edge with scotch tape to a board or table.
2. Place negative on top of recording, making certain that the recorded paper lines and the lines on the transparent negative coincide, then tacking by tape at righthand edge to table.
3. Fold recording and negative paper to either side, placing the photostatic paper in the vacated space and fix to table.
4. Replace the recorded curve on top of the photostatic paper.
5. Expose the combination by illumination.
6. Turn recording paper aside, replacing with negative, and maintaining it in the correct position, again carry out the exposure procedure.
7. Take the photostat and develop.

N.B. By illuminating the recording longer than the negative, a more pronounced picture of the curve will be obtained.

OPERATION

General.

The instruments contained in the A. F. Response and Spectrum Recorder can be used separately, or together, in various combinations. The logarithmic frequency scale of the B. F. O. 1014 allows it to be completely synchronized with the Spectrometer.

Synchronization.

To fully synchronize the three units the following sequence of operation is recommended. Switch on the power of each instrument and connect the "Recorder" terminal of the Spectrometer to the "Input" terminal of the Level Recorder, then calibrate as follows:—

BFO 1014 Section.

Calibrate the BFO as in "A. Calibration" under Operation on page 15. Spectrometer.

1. "Input Switch" to "Direct".
2. "Meter Range" to "Ref."
3. "Meter Switch" to "Fast" "RMS".
4. "Range Multiplier" to "x 1, 0 db".
5. "Function Selector" to "Linear, 2—40000 c/s".
6. "Automatic Switching" to "Off".

Other knobs in any position.

Meter should show a deflection to the red mark on the scale. If necessary any deviation can be recorded by means of the potentiometer marked "Sensitivity Amplifier Input" situated on the front panel. Adjust with screwdriver.

Level Recorder.

(N.B. In this case a 50 db potentiometer is used. For other ranges refer manual for Level Recorder Type 2305).

Set control knobs to the following positions:—

1. "Potentiometer Range db" to "50".
2. "Rectifier Response" to "RMS".
3. "Lower Limiting Frequency" to "20".
4. "Writing Speed":
 - 50 mm paper: 500 mm/sec. (large figures).
 - 100 mm paper: 1000 mm/sec. (small figures).
5. "Paper Drive" to "Stop" and "Forward" positions.
6. Motor to "On".
7. Set "Input Attenuator" to "10".
8. Using the "Input Potentiometer" adjust stylus to full deflection — 4 db (e. g. using 50 db Range it will be 50 db — 4 db = 46 db).
9. Insert the desired type of frequency calibrated paper. (If necessary refer Level Recorder Manual).

10. Pull the Synchronizing Gear Lever (1 : 10) marked "X" in Fig. 36 to outer position.
11. With a screwdriver turn the screw "S" on Fig. 36 until marking cut is in vertical position.
12. Set the "Paper Speed" to 10 mm/sec. (small figures). The spring loaded knob is operated by pulling, turning and dropping to correct position.

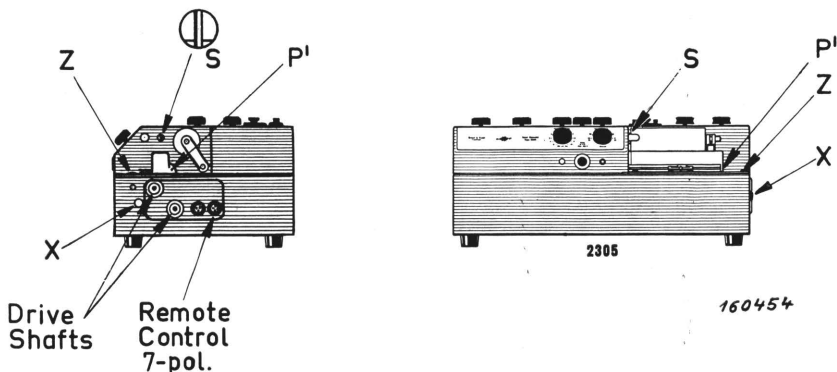

Fig. 36. Front and side views of Level Recorder.

13. The toggle switch "Paper Drive" is set to "Start" whereby the paper should start moving. If not, press the pushbutton "Single Chart — Continuous Recording" and release it again, the paper will move and after a chart length or less automatically stop.
14. Move the recording paper by means of the finger wheel "Z" shown in Fig. 36 until stylus rests on 10 c/s line.

At this stage final synchronization of the units takes place by firstly synchronizing the Spectrometer and Level Recorder sections as follows:—

Set the control knobs of the Spectrometer to:—

1. "Function Selector" to " $\frac{1}{3}$ Octave — 0 db".
2. "Filter Switch" to one step before (counter-clock-wise) the position "12.5".
3. "Automatic Switching" to "On".

Then the control knobs of the Level Recorder to:—

1. "Paper Drive" to Stop.
2. Press pushbutton marked "Single Chart" and hold in. (Paper will move and the reference voltage commences to record). Release pushbutton when paper has moved to about the "200" c/s line.
3. Units are correctly synchronized when switching from the 80 c/s to the 100 c/s filter takes place on the 90 c/s line.

4. As a means to see how far the paper has to be shifted, it is recommended to draw a line, by means of the "100 mV Ref." button on the front plate of the Recorder, at the point where the paper has stopped. By using this line as a reference the paper can be shifted the appropriate distance to give correct synchronization.
5. To check the synchronization, run the recording until the pen is stopped on for example the 2000 c/s line. When correctly synchronized, the switching of the 800 c/s to the 1000 c/s filter should now take place at the 900 c/s line. If this is not the case repeat from item 2.
6. Finally reset the Writing Speed on 250 mm or lower if the large figures are being used, and to a figure of 500 mm or less if using the small figures.

To complete the synchronization sequence the BFO must be synchronized with the frequency calibration on the paper.

1. Rotate main scale of BFO manually until it corresponds to the frequency denoted by the stylus, firstly moving it to a higher frequency and then rotating it back until it arrives on the desired frequency. This will take up any possible backlash with the gears of the BFO.
2. Move "Clutch Switching" of the BFO to the "On" position.
All units should now be in complete synchronization and on switching the toggle switch of the "Paper Drive" on the Recorder to "Start", the combination will operate in complete unison.

APPLICATIONS

Applications for the combined B. F. O. 1014 and Level Recorder 2305 have been described, and illustrated, under this heading in the earlier phase of this manual. Now one important use for the treble combination, B. F. O. + Level Recorder + Spectrometer (i.e. the A.F. Response and Spectrum Recorder Type 3326) will be described, followed by an other example using the Spectrometer and Level Recorder with the exclusion of the B. F. O. 1014 section.

Automatically Recording Harmonics.

The Type 3326 combination is well-suited for the automatic recording of harmonic distortion, as the Spectrometer can be switched to select any specific harmonic component of the fundamental in use, up to and including the 5th. In Fig. 37 the illustration shows an arrangement for the investigation of harmonic distortion in hearing aids.

As the distortion produced in the electronic assembly of such a unit (i. e. the amplifier only) is small, in comparison to distortion produced by the electro-

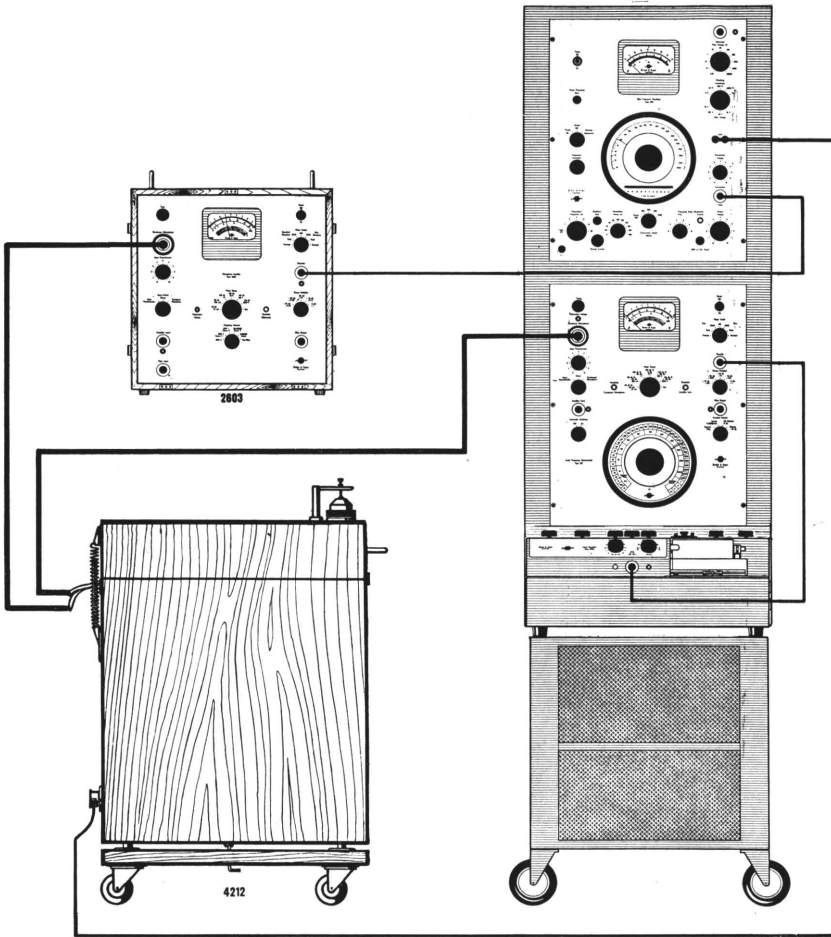

Fig. 37 (a) Measuring arrangement to measure harmonic distortion in hearing aids.

acoustical transducing stage, this portion must also be included in the examination.

Basically the set-up is the same as described under "Checking of Hearing Aids", page 35, with the exception that the output of the Artificial Ear on the Hearing Aid Test Box Type 4212, is fed to the input of the Spectrometer, instead of to the Microphone Amplifier Type 2603. When synchronization of the units as described on page 52 has been carried out, the measurements can commence.

In the case where the harmonics of a four-terminal network are to be automatically recorded, the synchronization of the units should have been completed and the Single Chart recording method should be utilized.

The harmonics are measured by setting the filter switch on the Spectrometer so that it runs ahead of the frequency scanning of the B. F. O., the selected frequency difference being in accordance with the harmonic which is going to be measured.

By means of the Reverse/Forward switch the recording is returned by the single chart length already run off; and the process repeated until all the required harmonics are recorded on the same chart as the fundamental.

The dips seen on the curve are due to the shape of the Spectrometer filter, and the manner of scanning the frequency range. When properly synchronized the "open" dips will occur with a depth that corresponds to around 3 db.

During measurements the sensitivity of the Spectrometer or the Level Recorder should not be altered. If, however, circumstances require an alteration to be made e.g. to obtain a clear recording of some of the

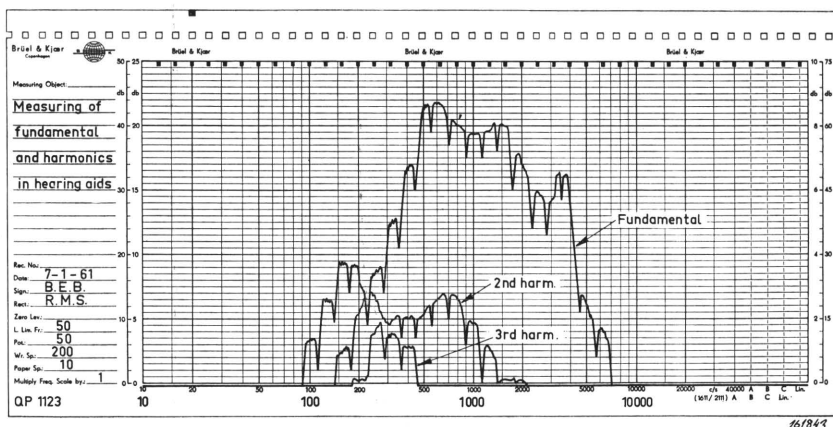

Fig. 37 (b) Recording obtained with set-up as shown in 37 (a).

harmonics, the gain of the Spectrometer can be increased by means of the "Range Multiplier" switch. (The "Meter Range" switch should not be used as it will tend to overdrive the amplifier stages). When using the Range Multiplier for this means, it must of course be taken into account in the evaluation of the final results.

Vibration Measurements.

By using one of the Accelerometer Sets Type 4308/09/10/11 with a Vibration Pick-up Preamplifier Type 1606, or one of the Microphone Cathode

Followers, vibrations in buildings, machinery, ships, etc., can be measured. In Fig. 38a a layout is shown, where the Type 3326 is being used to automatically record vibration measurements taken on the base of an electrical motor, the Spectrometer allowing an analysis of the vibrations to be made. The output from the Accelerometer is fed via the Preamplifier 1606 to the "Condenser Microphone" input of the Spectrometer. Information on the calibration of the arrangement is given in the manual for the Type 1606.

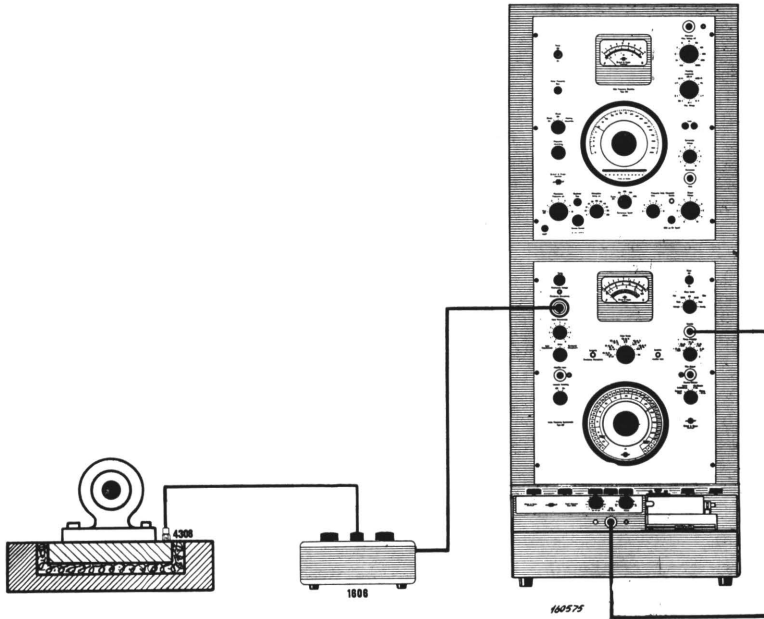

Fig. 38a. Set-up for vibration measurements on a motor installation.

Fig. 38b shows a recording of the vibrations from a synchronous motor which uses a 50 c/s mains supply. In this recording a 50 db Range Potentiometer was used in the Level Recorder, 0 db reference being equal to an acceleration of 25 cm/sec.².

Noise Measurements.

Noise within factories, offices, cities, airports, etc. varies with the time of day. Therefore it is a firm requirement that recordings of the noise should be carried out over a considerable period of time as a single recording taken at a particular instant would provide incorrect information.

Fig. 39 shows a recording taken of the noise level in a mechanical workshop over a selected period of time by using one of the Weighting Networks

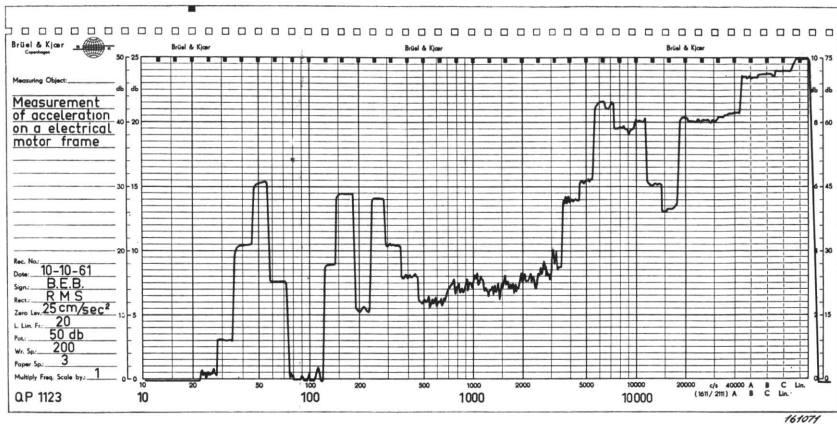

Fig. 38b. Recording obtained with measuring set-up as shown in Fig. 38a.

in the Spectrometer. As can be seen the noise level varies considerably with time and a reliable analysis cannot be obtained by only taking a few measurements. It is therefore necessary, when doing such a test, to record continuously and then to statistically assess the final result.

To measure, analyse and record such noise the Spectrometer + Level Recorder (i.e. the receiving part of the A.F. Response and Spectrum Recorder Type 3326) in combination with a B & K Condenser Microphone can be used.

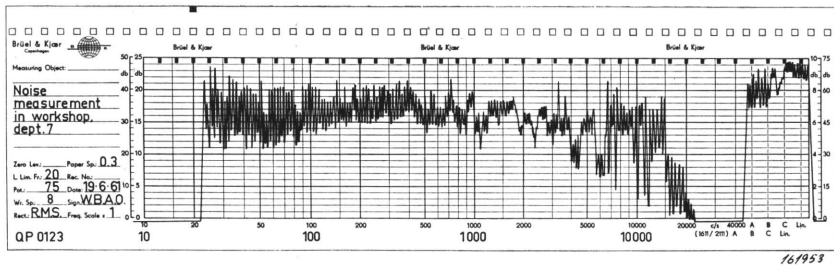

Fig. 39. Recording of the noise level in a mechanical workshop over a period of time.

Specification

Frequency Range: 20—20000 c/s.

Frequency Scales:

Main Scale: Logarithmic from 20—20000 c/s.

Tolerance ± 0.7 degrees of theoretical logarithmic curve. Vernier driven.

Increment Scale: Range -50 to $+50$ c/s of main scale reading. Both scales illuminated.

Frequency Accuracy:

Main scale: $1\% \pm 1$ c/s.

Increment scale: ± 0.5 c/s.

Outputs:

Matching: Switchable matching impedance for 6, 60, 600 or 6000 ohms load.

Max. power output 2.5 watts approx.

Attenuator: Variable in steps of 10 db (within ± 0.2 db) from 125 μ V to 12.5 V. Continuously variable by potentiometer within each step.

Output Voltage Accuracy: In frequency range 20 to 20000 c/s.

Better than ± 0.3 db on "Attenuator Output".

Better than ± 1 db on "Load" 1 watt loaded.

Voltmeter: Vacuum-tube voltmeter. Moving-coil. Illuminated mirrored scale.

Highly accurate, better than 1.5% of full-scale deflection. Perfectly safeguarded against overload.

Distortion:

Frequency in c/s	20	200	2000	20000
"Attenuator" terminal.				
No load with 10 V				
output approx.	1.0 %	0.1 %	0.1 %	0.7 %
"Load" terminal.				
(Loaded 1 watt)	2.0 %	0.3 %	0.3 %	1.2 %

Automatic Output Regulator: Output voltage automatically regulated when required. Built-in compressor amplifier maintains regulation up to 45 db and a constant voltage, current or sound pressure to within ± 2 db in

frequency range 50—20000 c/s. Input impedance 100 kohms. Regulation speed variable in steps: 30—100—300 and 1000 db/sec.

Frequency Modulation: Continuously variable modulation swing 0 to ± 200 c/s. Selectable modulated frequency by built-in saw-tooth oscillator of 1—2—4—8—16 and 32 c/s.

Oscillator Stop: Push-button Oscillator Stop for noiseless switching in reverberation measurements. Remote control available.

Frequency Scan: Worm gear in oscillator permits variable capacitor to be driven from motor of Level Recorder Type 2305. Connection achieved by flexible shaft. Magnetic clutch for set and release of drive. Clutch can be remotely controlled. Accurate synchronization with Level Recorder Frequency Calibrated Paper.

Tubes: 4 \times 12AT7 (ECC81) — 3 \times 6AU6 (EF94) — 6AL5 (EAA91) — 6BQ5 (EL84) — OA2.

Power Supply: 100 — 115 — 127 — 150 — 220 — 240 Volts AC. 50—400 c/s. Power consumption approximately 70 watts.

Dimensions:

Excl. dials and knobs	Height	Width	Depth
Centimetres	50	40	20
Inches	20	16	8
Weight	22 kg		49 lbs.

